



British Standards

BSI British Standards
389 Chiswick High Road
London W4 4AL
Tel: 020 8996 9000
Fax: 020 8996 7448
Web: <http://bsi-global.com>

DIRECT

Tel: +44(0) 20 8996 7416
Fax: +44(0) 20 8996 7448
E-mail: sharon.sinatra@bsi-org.com

To the Members of:

Technical Committee TCT/7

SUBJECT: CENELEC VOTE FINAL DRAFT PR EN 50173-1 INFORMATION TECHNOLOGY -GENERIC CABLING SYSTEMS PART 1:GENERAL REQUIREMENTS AND OFFICE AREAS. UK CLOSE DATE 9 SEPTEMBER 2002

Please find attached the final draft for prEN 50173-1 Information technology -Generic cabling systems Part 1:General requirements and office areas.

Please note that the UK close date is **9 September 2002**.

Yours sincerely

Sharon Sinatra
Associate Programme Manager
DISC
Secretary to TCT/7

Private circulation

Document: 02/637064

Our ref: **TCT/7**

Date: **18 June 2002**

English version

Information technology - Generic cabling systems
Part 1: General requirements and office areas

Technologies de l'information - Systèmes
génériques de câblage
Partie 1: Spécification générale et
environnement de bureaux

Informationstechnik -
Anwendungsneutrale
Kommunikationskabelanlagen
Teil 1: Allgemeine Anforderungen und
Bürobereiche

This draft European Standard is submitted to CENELEC members for formal vote.
Deadline for CENELEC: 2002-09-13

It has been drawn up by Technical Committee CENELEC TC 215.

If this draft becomes a European Standard, CENELEC members are bound to comply with the CEN/CENELEC Internal Regulations which stipulate the conditions for giving this European Standard the status of a national standard without any alteration.

This draft European Standard was established by CENELEC in three official versions (English, French, German). A version in any other language made by translation under the responsibility of a CENELEC member into its own language and notified to the Central Secretariat has the same status as the official versions.

CENELEC members are the national electrotechnical committees of Austria, Belgium, Czech Republic, Denmark, Finland, France, Germany, Greece, Hungary, Iceland, Ireland, Italy, Luxembourg, Malta, Netherlands, Norway, Portugal, Slovakia, Spain, Sweden, Switzerland and United Kingdom.

Warning : This document is not a European Standard. It is distributed for review and comments. It is subject to change without notice and shall not be referred to as a European Standard.

CENELEC

European Committee for Electrotechnical Standardization
Comité Européen de Normalisation Electrotechnique
Europäisches Komitee für Elektrotechnische Normung

Central Secretariat: rue de Stassart 35, B - 1050 Brussels

- 1 **Foreword**
- 2 This draft European Standard has been prepared by Technical Committee CENELEC/TC 215
3 „Electrotechnical aspects of telecommunication equipment" under the framework of the Mandates M/212 on
4 „Telecommunication cables and cabling systems" and M/239 on „Air traffic management equipment and
5 systems".
- 6 It is submitted to the Formal Vote.
- 7 The following dates are proposed:
- latest date by which the existence of the EN
has to be announced at national level (doa) dor + 6 months
 - latest date by which the EN has to be implemented
at national level by publication of an identical
national standard or by endorsement (dop) dor + 12 months
 - latest date by which the national standards
conflicting with the EN have to be withdrawn (dow) dor + 12 months
(to be confirmed or
modified when voting)
- 8 This European Standard supersedes both EN 50173:1995 and EN 50173:1995/A1:2000.
- 9 Annexes designated “normative” are a part of this standard. Annexes designated “informative” are for
10 information only. In this standard, Annexes A and D are normative, Annexes B, C, E, F and G are informative.
- 11 To ease the commenting of this draft line numbers have been included; they will be suppressed in the final
12 document.

13	Contents	
14	Introduction.....	10
15	1 Scope and conformance.....	12
16	1.1 Scope	12
17	1.2 Conformance	12
18	2 Normative references.....	13
19	3 Definitions and abbreviations.....	16
20	3.1 Definitions	16
21	3.2 Abbreviations	21
22	4 Structure of the generic cabling system.....	22
23	4.1 General	22
24	4.2 Functional elements.....	23
25	4.3 General structure and hierarchy	23
26	4.4 Cabling subsystems.....	25
27	4.5 Accommodation of functional elements.....	26
28	4.6 Interfaces	26
29	4.7 Dimensioning and configuring	28
30	4.8 Electromagnetic compatibility	32
31	4.9 Earthing and equipotential bonding	32
32	5 Channel performance.....	32
33	5.1 General	32
34	5.2 Layout of channels.....	33
35	5.3 Classification of balanced cabling channels	34
36	5.4 Balanced cabling channel performance.....	34
37	5.5 Classification of optical fibre cabling channels	44
38	6 Reference implementations	45
39	6.1 General	45
40	6.2 Balanced cabling.....	45
41	6.3 Optical fibre cabling	50
42	7 Cable requirements.....	52
43	7.1 General	52
44	7.2 Balanced cables.....	52

45	7.3	Hybrid and multi-unit cables, and cables connected to more than	
46		one telecommunications outlet	53
47	7.4	Optical fibre cables	53
48	8	Connecting hardware requirements.....	54
49	8.1	General requirements	54
50	8.2	Connecting hardware for balanced cabling	56
51	8.3	Optical fibre connecting hardware	66
52	9	Requirements for cords and jumpers	68
53	9.1	General	68
54	9.2	Balanced cords	68
55	9.3	Optical fibre cords	71
56	Annex A	(normative) Link performance limits	72
57	A.1	General	72
58	A.2	Balanced cabling.....	72
59	A.3	Optical fibre cabling	79
60	Annex B	(informative) Permanent link performance limits for maximum implementation	80
61	B.1	General	80
62	B.2	Performance limits	80
63	Annex C	(informative) Class F channel and permanent link with two connections	84
64	Annex D	(normative) Mechanical and environmental performance testing of balanced cabling	
65		connecting hardware of types other than those used at the TO	85
66	D.1	Introduction	85
67	D.2	Test requirements	85
68	Annex E	(informative) Supported Applications	90
69	E.1	Supported applications for balanced cabling.....	90
70	E.2	Supported applications for optical fibre cabling	90
71	Annex F	(informative) Electromagnetic characteristics.....	96
72	Annex G	(informative) Changes from earlier editions of this European Standard	97
73	G.1	General	97
74	G.2	Cabling structure.....	97
75	G.3	Installed balanced cabling requirements	98
76	Bibliography		102

77	Figures	
78	Figure 1 – Relationship between EN 50173-1 and other standards relevant for	
79	information technology cabling systems.....	11
80	Figure 2 - Structure of generic cabling	23
81	Figure 3 – Hierarchical structure of generic cabling.....	24
82	Figure 4 – Structures for centralized generic cabling.....	24
83	Figure 5 - Accommodation of functional elements	26
84	Figure 6- Interconnect and cross-connect models	27
85	Figure 7 - Test and equipment interfaces.....	27
86	Figure 8 - Example of a generic cabling system with combined BD and FD	29
87	Figure 9 - Connection of functional elements providing redundancy.....	30
88	Figure 10 - Example of a system showing the location of cabling interfaces.....	33
89	Figure 11 - Horizontal cabling models.....	48
90	Figure 12 - Backbone cabling model.....	49
91	Figure 13 - Combined optical fibre backbone/horizontal channels	51
92	Figure 14 - Eight position jack pin and pair grouping assignments (front view of connector).....	65
93	Figure A.1 - Link options.....	72
94	Figure C.1 – Two connection channel and permanent link	84
95	Figure G.1 - Horizontal cabling model.....	98
96	Figure G.2 - Backbone cabling model.....	98
97		

98	Tables	
99	Table 1 - Maximum channel lengths for reference implementations.....	28
100	Table 2 - Formulae for return loss limits for a channel.....	35
101	Table 3 - Return loss limits for a channel at key frequencies.....	35
102	Table 4 - Formulae for attenuation limits for a channel.....	36
103	Table 5 - Attenuation limits for a channel at key frequencies.....	36
104	Table 6 - Formulae for NEXT limits for a channel.....	37
105	Table 7 - NEXT limits for a channel at key frequencies.....	37
106	Table 8 - Formulae for PSNEXT limits for a channel.....	38
107	Table 9 - PSNEXT limits for a channel at key frequencies.....	38
108	Table 10 - ACR limits for a channel at key frequencies.....	39
109	Table 11 - PSACR limits for a channel at key frequencies.....	39
110	Table 12 - Formulae for ELFEXT limits for a channel.....	40
111	Table 13 - ELFEXT limits for a channel at key frequencies.....	40
112	Table 14 - Formulae for PSELFEXT limits for a channel.....	41
113	Table 15 - PSELFEXT limits for a channel at key frequencies.....	41
114	Table 16 - Maximum d.c. loop resistance values for a channel.....	42
115	Table 17 - Formulae for propagation delay limits for a channel.....	42
116	Table 18 - Propagation delay limits for a channel at key frequencies.....	43
117	Table 19 - Delay skew limits for a channel.....	43
118	Table 20 - Maximum unbalance attenuation, near end.....	43
119	Table 21 - Optical fibre channel attenuation limits.....	44
120	Table 22 - Horizontal channel equations.....	46
121	Table 23 - Backbone channel equations.....	50
122	Table 24 - Optical fibre channel parameters.....	52
123	Table 25 - Balanced cable standards.....	53
124	Table 26 - Multimode optical fibre cable performance requirements.....	53

125	Table 27 - Singlemode optical fibre cable (Category OS1) performance requirements	54
126	Table 28 - Mechanical characteristics of connecting hardware intended for use with balanced cabling.....	57
127	Table 29 - Backwards compatibility matrix.....	58
128	Table 30 - Formulae for return loss limits for connecting hardware.....	58
129	Table 31 - Minimum return loss.....	58
130	Table 32 - Formulae for attenuation limits for connecting hardware.....	59
131	Table 33 - Maximum attenuation (insertion loss)	59
132	Table 34 – Formulae for NEXT limits for connecting hardware	59
133	Table 35 - Minimum NEXT	59
134	Table 36 - Formulae for PS NEXT limits for connecting hardware	60
135	Table 37 - Minimum PSNEXT	60
136	Table 38- Formulae for FEXT limits for connecting hardware.....	60
137	Table 39 - Minimum FEXT	61
138	Table 40 - Formulae for PSFEXT limits for connecting hardware.....	61
139	Table 41 - Minimum PSFEXT.....	61
140	Table 42 - Formulae for propagation delay for connecting hardware	61
141	Table 43 - Formulae for delay skew for connecting hardware	62
142	Table 44 – Maximum input to output resistance.....	62
143	Table 45 – Maximum input to output resistance unbalance.....	62
144	Table 46 - Minimum current carrying capacity	63
145	Table 47 - Formulae for transfer impedance for connecting hardware	63
146	Table 48 - Maximum transfer impedance.....	63
147	Table 49 - Formulae for Transverse Conversion Loss (TCL) limits for connecting hardware	64
148	Table 50 - Minimum TCL.....	64
149	Table 51 – Minimum insulation resistance	64
150	Table 52 – Minimum d.c. voltage proof	64
151	Table 53 – Connecting hardware requirements at the telecommunications outlet	65

152	Table 54 - Mechanical and optical characteristics of optical fibre connecting hardware	67
153	Table 55 – Return loss requirements for cords	69
154	Table 56 - Informative values of NEXT at key frequencies for Category 5, 6 and 7 cords	70
155	Table A.1 - Formulae for return loss limits for a link.....	73
156	Table A.2 - Formulae for attenuation limits for a link.....	74
157	Table A.3 - Formulae for NEXT limits for a link	75
158	Table A.4 - Formulae for PSNEXT limits for a link	75
159	Table A.5 - Formulae for ELFEXT limits for a link.....	76
160	Table A.6 - Formulae for PSELFEXT limits for a link	77
161	Table A.7 – Direct current (d.c.) loop resistance limits for a link.....	77
162	Table A.8 - Propagation delay formulae for a link	78
163	Table A.9 - Delay skew formulae for a link.....	79
164	Table B.1 - Return loss limits for a permanent link at key frequencies	80
165	Table B.2 - Attenuation limits for a permanent link at key frequencies	80
166	Table B.3 - NEXT limits for a permanent link at key frequencies.....	81
167	Table B.4 - PSNEXT limits for a permanent link at key frequencies	81
168	Table B.5 - ACR limits for a permanent link at key frequencies.....	81
169	Table B.6 - PSACR limits for a permanent link at key frequencies	82
170	Table B.7 - ELFEXT limits for a permanent link at key frequencies.....	82
171	Table B.8 - PSELFEXT limits for a permanent link at key frequencies.....	82
172	Table B.9 – Direct current (d.c.) loop resistance limits for a permanent link at key frequencies	83
173	Table B.10 - Propagation delay limits for a permanent link at key frequencies	83
174	Table B.11 - Delay skew limits for a permanent link at key frequencies.....	83
175	Table C.1 - ACR and PSACR values for 2 connection class F channels and	
176	permanent links at key frequencies.....	84
177	Table D.1 - Test group P	86
178	Table D.2 - Test group AP.....	87

179	Table D.3 - Test group BP	88
180	Table D.4 - Test group CP.....	88
181	Table D.5 - Test group DP.....	89
182	Table E.1 - Supported applications using balanced cabling	91
183	Table E.2 - Modular connector pin assignment for applications	92
184	Table E.3 - Supported applications using optical fibre cabling.....	93
185	Table E.4 - Maximum channel lengths supported by optical fibre applications with multimode fibres	94
186	Table E.5 - Maximum channel lengths supported by optical fibre applications with singlemode fibres.....	95
187	Table G.1 - Maximum attenuation	99
188	Table G.2 - Minimum NEXT	99
189	Table G.3 - Minimum ACR	100
190	Table G.4 - Minimum Return loss.....	100
191	Table G.5 - Minimum LCL/LCTL	100
192	Table G.6 - Maximum Delay.....	101
193	Table G.7 - Maximum d.c. loop resistance.....	101
194	Table G.8 – Class D Power sum values.....	101
195	Table G.9 - Delay skew	102
196		

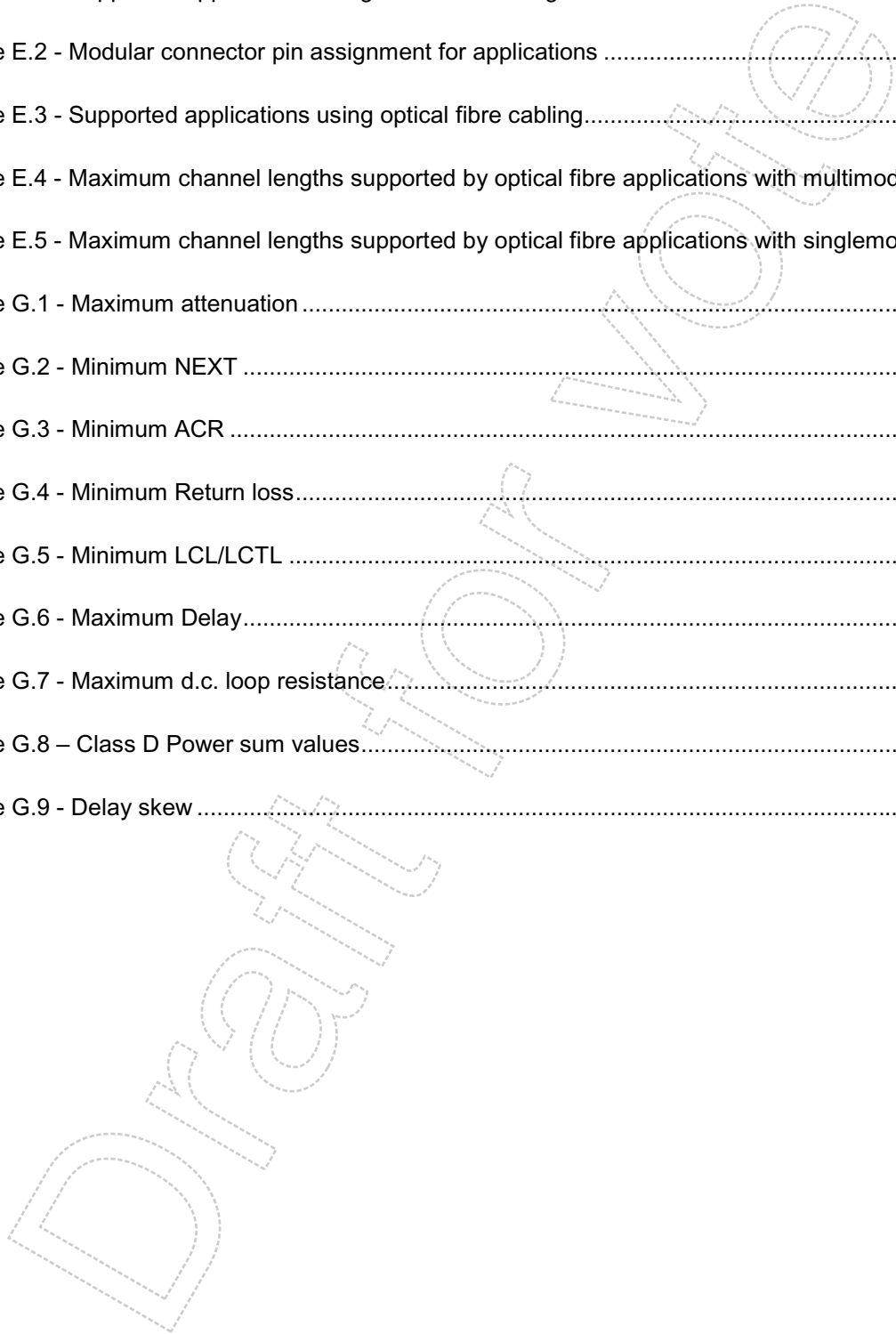

197 Introduction

198 Within premises, the importance of the information technology cabling infrastructure is similar to that of other
199 fundamental building utilities such as heating, lighting and mains power. As with other utilities, interruptions to
200 service can have serious impact. Poor quality of service due to lack of design foresight, use of inappropriate
201 components, incorrect installation, poor administration or inadequate support can threaten an organisation's
202 effectiveness.

203 Historically, the cabling within a premises comprised both application-specific and multipurpose networks.
204 The previous edition of this standard enabled a controlled migration to generic cabling and the reduction in
205 the use of application-specific cabling. The subsequent growth of generic cabling designed in accordance
206 with EN 50173 has supported the development of high data rate applications based upon a defined cabling
207 model. This edition, EN 50173-1, has been revised to reflect these increasing demands.

208 This European Standard provides:

209 a) users with an application independent generic cabling system and an open market for cabling compo-
210 nents;

211 b) users with a flexible cabling scheme such that modifications are both easy and economical;

212 c) building professionals (for example, architects) with guidance allowing the accommodation of cabling
213 before specific requirements are known; i.e., in the initial planning either for construction or refurbishment;

214 d) industry and standardisation bodies with a cabling system which supports current products and provides a
215 basis for future product development and applications standardisation.

216 This European Standard specifies multi-vendor cabling, and is related to:

217 - standards for cabling components developed by Technical Committees of CENELEC and/or IEC;

218 - standards for the quality assurance and installation of information technology cabling (series EN 50174)
219 and testing of installed cabling (EN 50346);

220 - applications developed by the subcommittees of ISO/IEC JTC 1 and study groups of ITU-T..

221 The applications listed in Annex E have been analysed to determine the requirements for a generic cabling
222 system. These requirements, together with statistics concerning premises geography from different countries
223 and the models described in Clause 6, have been used to develop the requirements for cabling components
224 and to stipulate their arrangement into cabling systems. As a result, generic cabling defined within this
225 European Standard is targeted at, but not limited to, the general office environment.

226 It is anticipated that the generic cabling system meeting the minimum requirements of this European
227 Standard will have a life expectancy in excess of ten years.

228 Figure 1 shows the relationships between the standards produced by TC 215 for information technology
229 cabling, namely this generic cabling design standard, cabling installation standards (EN 50174 series), testing
230 of installed cabling (EN 50346) and equipotential bonding requirements (EN 50310).

231

Building design phase	Generic cabling design phase	Planning phase	Implementation phase	Operation phase
<p>EN 50310</p> <p>5.2: Common bonding network (CBN) within a building</p> <p>6.3: AC distribution system and bonding of the protective conductor (TN-S)</p>	<p>EN 50173-1</p> <p>4: Topology</p> <p>5: Channel performance</p> <p>7: Cable requirements</p> <p>8: Connecting hardware requirements</p> <p>9: Requirements for cords</p> <p>A.1: Link performance limits</p>	<p>EN 50174-1</p> <p>4: Specification considerations</p> <p>5: Quality assurance</p> <p>7: Cabling administration</p> <p>and</p> <p>EN 50174-2</p> <p>4: Safety requirements</p> <p>5: General installation practices for metallic and optical fibre cabling</p> <p>6: Additional installation practice for metallic cabling</p> <p>7: Additional installation practice for optical fibre cabling</p> <p>and</p> <p>EN 50174-3</p> <p>and</p> <p>(for equipotential bonding)</p> <p>EN 50310</p> <p>5.2: Common bonding network (CBN) within a building</p> <p>6.3: AC distribution system and bonding of the protective conductor (TN-S)</p>	<p>EN 50174-1</p> <p>6: Documentation</p> <p>7: Cabling administration</p> <p>and</p> <p>EN 50174-2</p> <p>4: Safety requirements</p> <p>5: General installation practices for metallic and optical fibre cabling</p> <p>6: Additional installation practice for metallic cabling</p> <p>7: Additional installation practice for optical fibre cabling</p> <p>and</p> <p>EN 50174-3</p> <p>and</p> <p>(for equipotential bonding)</p> <p>EN 50310</p> <p>5.2: Common bonding network (CBN) within a building</p> <p>6.3: AC distribution system and bonding of the protective conductor (TN-S)</p> <p>and</p> <p>EN 50346</p> <p>4: General requirements</p> <p>5: Test parameters for balanced cabling</p> <p>6: Test parameters for optical fibre cabling</p>	<p>EN 50174-1</p> <p>5: Quality assurance</p> <p>7: Cabling administration</p> <p>8: Repair and maintenance</p>

Figure 1 – Relationship between EN 50173-1 and other standards relevant for information technology cabling systems

232

233

234

235 1 Scope and conformance

236 1.1 Scope

237 This European Standard specifies generic cabling for use within premises which may comprise single or
238 multiple buildings on a campus. It covers balanced cabling and optical fibre cabling.

239 The standard is optimised for premises in which the maximum distance over which telecommunications
240 services have to be distributed is 2 000 m. The principles of this European Standard may also be applied to
241 larger installations.

242 Cabling defined by this standard supports a wide range of services including voice, data, text, image and
243 video.

244 This European Standard specifies:

- 245 a) the structure and configuration for generic cabling;
- 246 b) cabling performance requirements;
- 247 c) implementation options.

248 Safety (electrical safety and protection, fire, etc.) and electromagnetic compatibility (EMC) requirements are
249 outside the scope of this European Standard and are covered by other standards and regulations. However,
250 information given in this European Standard may be of assistance in meeting these standards and
251 regulations.

252 1.2 Conformance

253 For a cabling system to conform to this European Standard:

- 254 a) the structure and configuration shall conform to the requirements of Clause 4;
- 255 b) the interfaces to the cabling at the telecommunications outlet shall conform to the requirements of
256 Clause 8 with respect to mating interfaces and performance;
- 257 c) connecting hardware at other places in the cabling structure shall meet the performance requirements
258 specified in Clause 8;
- 259 d) the performance of channels shall conform to the requirements of Clause 5;
- 260 e) local regulations concerning safety shall be met.

261 The performance of balanced channels shall meet the requirements specified in Clause 5 This shall be
262 achieved by one of the following:

- 263 – a channel design and implementation ensuring that the prescribed channel performance class of Clause 5
264 is met;
- 265 – attachment of appropriate components to a link design meeting the prescribed performance class of
266 Annex A. Channel performance shall be assured where a channel is created by adding more than one
267 cord to either end of a link meeting the requirements of Annex A;
- 268 – using the reference implementations of Clause 6 and compatible cabling components conforming to the
269 requirements of Clauses 7, 8 and 9, based upon a statistical approach of performance modelling.

270 Test methods to ensure conformance with the channel and link requirements of Clause 5 and Annex A
271 respectively are specified in EN 50346. The treatment of measured results that fail to meet the requirements of
272 this clause, or lie within the relevant measurement accuracy, shall be clearly documented within a quality plan as
273 described in EN 50174-1.

274 Installation and administration of cabling in accordance with this European standard should be undertaken in
275 accordance with the EN 50174 series of standards.

276 This standard does not specify which tests and sampling levels should be adopted. The test parameters to be
277 measured and the sampling levels to be applied for a particular installation should be defined in the
278 installation specification and quality plans for that installation prepared in accordance with EN 50174-1.

279 Specifications marked "ffs" (for further study) are preliminary and are not required for conformance to this
280 European Standard.

281 **2 Normative references**

282 This European Standard incorporates by dated or undated reference, provisions from other publications.
283 These normative references are cited at the appropriate places in the text and the publications are listed
284 hereafter. For dated references, subsequent amendments to or revisions of any of these publications apply to
285 this European Standard only when incorporated in it by amendment or revision. For undated references the
286 latest edition of the publication referred to applies.

287 *EDITORIAL NOTE: To be updated before publication*

288 EN 50174-1, *Information technology - Cabling installation – Part 1: Specification and quality assurance.*

289 EN 50174-2, *Information technology – Cabling installation – Part 2: Installation planning and practices inside*
290 *buildings.*

291 EN 50174-3 ¹⁾, *Information technology - Cabling system installation – Part 3: Installation planning and*
292 *practices external to buildings.*

293 EN 50288-1, *Multi-element metallic cables used in analogue and digital communication and control – Part 1:*
294 *Generic specification.*

295 EN 50288-2-1 ²⁾, *Multi-element metallic cables used in analogue and digital communication and control –*
296 *Part 2-1: Sectional specification for screened cables characterized up to 100 MHz – Horizontal and building*
297 *backbone cables.*

298 EN 50288-2-2 ²⁾, *Multi-element metallic cables used in analogue and digital communication and control –*
299 *Part 2-2: Sectional specification for screened cables characterized up to 100 MHz – Work area and patch*
300 *cord cables.*

301 EN 50288-3-1 ²⁾, *Multi-element metallic cables used in analogue and digital communication and control –*
302 *Part 3-1: Sectional specification for unscreened cables characterized up to 100 MHz - Horizontal and building*
303 *backbone cables.*

304 EN 50288-3-2 ²⁾, *Multi-element metallic cables used in analogue and digital communication and control –*
305 *Part 3-2: Sectional specification for unscreened cables characterized up to 100 MHz – Work area and patch*
306 *cord cables.*

307 EN 50288-4-1 ²⁾, *Multi-element metallic cables used in analogue and digital communication and control –*
308 *Part 4-1: Sectional specification for screened cables characterized up to 600 MHz – Horizontal and building*
309 *backbone cables.*

310 EN 50288-4-2 ²⁾, *Multi-element metallic cables used in analogue and digital communication and control –*
311 *Part 4-2: Sectional specification for screened cables characterized up to 600 MHz – Work area and patch*
312 *cord cables.*

1) At draft stage (CEN/CENELEC enquiry).

2) Approved for Unique Acceptance Procedure (UAP) by CLC/SC 46XC.

- 313 EN 50288-5-1 ²⁾, *Multi-element metallic cables used in analogue and digital communication and control –*
314 *Part 5-1: Sectional specification for screened cables characterized up to 250 MHz – Horizontal and building*
315 *backbone cables.*
- 316 EN 50288-5-2 ²⁾, *Multi-element metallic cables used in analogue and digital communication and control –*
317 *Part 5-2: Sectional specification for screened cables characterized up to 250 MHz – Work area and patch*
318 *cord cables.*
- 319 EN 50288-6-1 ²⁾, *Multi-element metallic cables used in analogue and digital communication and control –*
320 *Part 6-1: Sectional specification for unscreened cables characterized up to 250 MHz – Horizontal and building*
321 *backbone cables.*
- 322 EN 50288-6-2 ²⁾, *Multi-element metallic cables used in analogue and digital communication and control –*
323 *Part 6-2: Sectional specification for unscreened cables characterized up to 250 MHz – Work area and patch*
324 *cord cables.*
- 325 EN 50289-1-6, *Communication cables - Specifications for test methods – Part 1-6: Electrical test methods –*
326 *Electromagnetic performance.*
- 327 EN 50310, *Application of equipotential bonding and earthing in buildings with information technology*
328 *equipment.*
- 329 EN 50346, *Information technology – Cabling installation – Testing of installed cabling.*
- 330 EN 60068-2-14, *Environmental testing - Part 2: Tests - Test N: Change of temperature (IEC 60068-2-14:1984*
331 *+ A1:1986).*
- 332 EN 60068-2-38, *Environmental testing - Part 2: Tests - Test ZIAD: Composite temperature/humidity cyclic*
333 *test (IEC 60068-2-38:1999).*
- 334 EN 60352-3, *Solderless connections – Part 3: Solderless accessible insulation displacement connections -*
335 *General requirements, test methods and practical guidance (IEC 60352-3:1993).*
- 336 EN 60352-4, *Solderless connections - Part 4: Solderless non-accessible insulation displacement connections*
337 *- General requirements, test methods and practical guidance (IEC 60352-4:1994).*
- 338 EN 60352-6, *Solderless connections - Part 6: Solderless insulation piercing connections - General*
339 *requirements, test methods and practical guidance (IEC 60352-6:1997).*
- 340 EN 60512-25-1, *Connectors for electronic equipment - Tests and measurements - Part 25-1: Test 25a –*
341 *Crosstalk ratio (IEC 60512-25-1:2001).*
- 342 EN 60512-25-2, *Electromechanical components for electronic equipment – Basic testing procedures and*
343 *measuring methods - Part 25-2: High speed electronics tests – Test 25b Attenuation/insertion loss*
344 *(IEC 60512-25-2:2002).*
- 345 EN 60512-25-3, *Connectors for electronic equipment - Tests and measurements - Part 25-3: Test 25c - Rise*
346 *time degradation (IEC 60512-25-3:2001).*
- 347 EN 60512-25-4, *Connectors for electronic equipment - Tests and measurements - Part 25-4: Test 25d –*
348 *Propagation delay (IEC 60512-25-4:2001).*
- 349 EN 60512-25-5 ³⁾, *Connectors for electronic equipment - Tests and measurements - Part 25-5: Test*
350 *25e – Return loss (IEC 60512-25-5:200x).*
- 351 EN 60603-7, *Connectors for frequencies below 3 MHz for use with printed boards – Part 7: Detail*
352 *specification for connectors, 8 way, including fixed and free connectors with common mating features*
353 *(IEC 60603-7:1996).*
- 354 EN 60603-7-2 ³⁾, *Connectors for use in d.c. low frequency analogue and in digital high speed data*
355 *applications – Part 7-2: Detail specification for 8 way connectors, with assessed quality, including fixed and*
356 *free connectors with common mounting features; test methods and related requirements for use at*
357 *frequencies up to 100 MHz.*
- 358 EN 60603-7-3 ³⁾, *Connectors for use in d.c. low frequency analogue and in digital high speed data*
359 *applications – Part 7-3:*

2) Approved for Unique Acceptance Procedure (UAP) by CLC/SC 46XC.

3) In preparation by IEC/SC 48B.

- 360 EN 60603-7-4 ³⁾, *Connectors for use in d.c. low frequency analogue and in digital high speed data*
361 *applications – Part 7-4: Connectors for electronic equipment: Detail specification for an 8 way connector with*
362 *performance up to 250 MHz.*
- 363 EN 60603-7-5 ³⁾, *Connectors for use in d.c. low frequency analogue and in digital high speed data*
364 *applications – Part 7-5:*
- 365 EN 60603-7-7, *Connectors for use in d.c. low frequency analogue and in digital high speed data applications*
366 *– Part 7-7: 8 way connectors for frequencies up to 600 MHz [Category 7 Detail Specification]*
367 *(IEC 60603-7-7:2002).*
- 368 EN 60793-1-40, *Optical fibres - Part 1-40: Measurement methods and test procedures – Attenuation*
369 *(IEC 60793-1-40:2001).*
- 370 EN 60793-1-41, *Optical fibres - Part 1-41: Measurement methods and test procedures - Bandwidth*
371 *(IEC 60793-1-41:2001).*
- 372 EN 60793-1-44, *Optical fibres - Part 1-44: Measurement methods and test procedures - Cut-off wavelength*
373 *(IEC 60793-1-44:2001).*
- 374 EN 60793-1-49, *Optical fibres - Part 1-49: Measurement methods and test procedures - Differential mode*
375 *delay (IEC 60793-1-49:200X).*
- 376 EN 60793-2-10, *Optical fibres - Part 2-10: Product specifications - Sectional specification for category A1*
377 *multimode fibres (IEC 60793-2-10:2002).*
- 378 EN 60793-2-50, *Optical fibres - Part 2-50: Product specifications - Sectional specification for class B single-*
379 *mode fibres(IEC 60793-2-50:2002).*
- 380 EN 60794-1-1, *Optical fibre cables - Part 1-1: Generic specification – General (IEC 60794-1-1:1999).*
- 381 EN 60794-1-2, *Optical fibre cables - Part 1-2: Generic specification - Basic optical cable test procedures*
382 *(IEC 60794-1-2:1999).*
- 383 EN 60794-3, *Optical fibre cables – Part 3: Telecommunication cables - Sectional specification*
384 *(IEC 60794-3:1998).*
- 385 EN 60811-1-1, *Insulating and sheathing of electric cables – Common test methods - Part 1: General*
386 *application – Section 1: Measurement of thickness and overall dimensions - Tests for determining the*
387 *mechanical properties (IEC 60811-1-1:1993).*
- 388 EN 60825-2, *Safety of laser products – Part 2: Safety of optical fibre communication systems*
389 *(IEC 60825-2:2000).*
- 390 EN 61073-1, *Mechanical splices and fusion splice protectors for optical fibres and cables - Part 1: Generic*
391 *specification (IEC 61073-1:2000).*
- 392 EN 61280-4-2, *Fibre optic communication subsystem basic test procedures – Part 4-2: Fibre optic cable plant*
393 *- Single-mode fibre optic cable plant attenuation (IEC 61280-4-2:1999).*
- 394 EN 61300-2-1, *Fibre optic interconnecting devices and passive components - Basic test and measurement*
395 *procedures - Part 2-1: Tests - Vibrations (sinusoidal) (IEC 61300-2-1:1995).*
- 396 EN 61300-2-2, *Fibre optic interconnecting devices and passive components - Basic test and measurement*
397 *procedures - Part 2-2: Tests - Mating durability (IEC 61300-2-2:1995).*
- 398 EN 61300-2-4, *Fibre optic interconnecting devices and passive components - Basic test and measurement*
399 *procedures - Part 2-4: Tests - Fibre/cable retention (IEC 61300-2-4:1995).*
- 400 EN 61300-2-6, *Fibre optic interconnecting devices and passive components - Basic test and measurement*
401 *procedures - Part 2-6: Tests - Tensile strength of coupling mechanism (IEC 61300-2-6:1995).*
- 402 EN 61300-2-12, *Fibre optic interconnecting devices and passive components - Basic test and measurement*
403 *procedures - Part 2-12: Tests - Impact (IEC 61300-2-12:1995).*
- 404 EN 61300-2-17, *Fibre optic interconnecting devices and passive components - Basic test and measurement*
405 *procedures - Part 2-17: Tests - Cold (IEC 61300-2-17:1995).*
- 406 EN 61300-2-18, *Fibre optic interconnecting devices and passive components - Basic test and measurement*
407 *procedures - Part 2-18: Tests - Dry heat - High temperature endurance (IEC 61300-2-18:1995).*
- 408 EN 61300-2-19, *Fibre optic interconnecting devices and passive components - Basic test and measurement*
409 *procedures - Part 2-19: Tests - Damp heat (steady state) (IEC 61300-2-19:1995).*

- 410 EN 61300-2-22, *Fibre optic interconnecting devices and passive components - Basic test and measurement*
411 *procedures - Part 2-22: Tests - Change of temperature (IEC 61300-2-22:1995).*
- 412 EN 61300-2-42, *Fibre optic interconnecting devices and passive components - Basic test and measurement*
413 *procedures - Part 2-42: Tests - Static side load for connectors (IEC 61300-2-42:1998).*
- 414 EN 61300-3-6, *Fibre optic interconnecting devices and passive components - Basic test and measurement*
415 *procedures - Part 3-6: Examinations and measurements - Return loss (IEC 61300-3-6:1997).*
- 416 EN 61300-3-34, *Fibre optic interconnecting devices and passive components - Basic test and measurement*
417 *procedures - Part 3-34: Examinations and measurements - Attenuation of random mated connectors*
418 *(IEC 61300-3-34:1997).*
- 419 EN 61935-2⁴⁾, *Generic cabling systems - Specification for the testing of balanced communication cabling in*
420 *accordance with ISO/IEC 11801 - Part 2: Patch cords and work area cabling (IEC 61935-2:200X).*
- 421 IEC 60512-2, *Electromechanical components for electronic equipment – Basic testing procedures and*
422 *measuring methods – Part 2: General Examination, electrical continuity and contact resistance tests,*
423 *insulation tests and voltage stress tests.*
- 424 IEC 60512-3, *Electromechanical components for electronic equipment – Basic testing procedures and*
425 *measuring methods – Part 3: Current-carrying capacity tests.*
- 426 IEC 60793-2, *Optical fibres – Part 2: Product specifications.*
- 427 IEC 60794-2, *Optical fibre cables – Part 2: Product specifications.*
- 428 IEC 60874-19-1, *Connectors for optical fibres and cables – Part 19-1: Fibre optic patch cord connector type*
429 *SC-PC (floating duplex) standard terminated on multimode fibre type A1a, A1b – Detail specification.*
- 430 IEC 61073-1, *Splices for optical fibres and cables – Part 1: Generic specification - Hardware and accessories.*

431 **3 Definitions and abbreviations**

432 **3.1 Definitions**

433 For the purposes of this European Standard the following definitions apply.

434 **3.1.1**

435 **administration**

436 methodology defining the documentation requirements of a cabling system and its containment, the labelling
437 of functional elements and the process by which moves, additions and changes are recorded

438 **3.1.2**

439 **application**

440 system, with its associated transmission method that is supported by telecommunications cabling

441 **3.1.3**

442 **balanced cable**

443 cable consisting of one or more symmetrical metallic cable elements (twisted pairs or quads)

444 **3.1.4**

445 **building backbone cable**

446 cable that connects the building distributor to a floor distributor. Building backbone cables may also connect
447 floor distributors in the same building

448 **3.1.5**

449 **building distributor**

450 distributor in which the building backbone cable(s) terminate(s) and at which connections to the campus
451 backbone cable(s) may be made

4) In preparation by IEC/SC 46A.

- 452 **3.1.6**
453 **building entrance facility**
454 facility that provides all necessary mechanical and electrical services, that complies with all relevant
455 regulations, for the entry of telecommunications cables into a building
- 456 **3.1.7**
457 **cable**
458 assembly of one or more cable units of the same type and category in an overall sheath. It may include an
459 overall screen
- 460 **3.1.8**
461 **cable element**
462 smallest construction unit in a cable. A cable element may have a screen
- 463 NOTE A pair, a quad and a single fibre are examples of a cable element.
- 464 **3.1.9**
465 **cable unit**
466 single assembly of one or more cable elements usually of the same type or category. The cable unit may
467 have a screen
- 468 **3.1.10**
469 **cabling**
470 system of telecommunications cables, cords and connecting hardware that supports the operation of
471 information technology equipment
- 472 **3.1.11**
473 **campus**
474 premises containing one or more buildings
- 475 **3.1.12**
476 **campus backbone cable**
477 cable that connects the campus distributor to the building distributor(s). Campus backbone cables may also
478 interconnect building distributors
- 479 **3.1.13**
480 **campus distributor**
481 distributor from which the campus backbone cabling emanates
- 482 **3.1.14**
483 **channel**
484 end to end transmission path connecting any two pieces of application-specific equipment. Equipment cords
485 and work area cords are included in the channel
- 486 **3.1.15**
487 **connection**
488 mated device or combination of devices including terminations used to connect cables or cable elements to
489 other cables, cable elements or application specific equipment
- 490 **3.1.16**
491 **consolidation point**
492 connection point in the horizontal cabling subsystem between a floor distributor and a telecommunications
493 outlet
- 494 **3.1.17**
495 **consolidation point cable**
496 **CP cable**
497 cable connecting a consolidation point to a telecommunications outlet

- 498 **3.1.18**
499 **consolidation point link**
500 **CP link**
501 transmission path between a consolidation point and the interface at the other end of the fixed horizontal
502 cable including the connecting hardware at each end
- 503 **3.1.19**
504 **cord**
505 cable unit or element with a minimum of one termination
- 506 **3.1.20**
507 **cross-connect**
508 a method of connecting a cabling subsystem to equipment (or another cabling subsystem) by the use of a
509 patch cord or jumper
- 510 **3.1.21**
511 **distributor**
512 term used for the functions of a collection of components (for example, patch panels, patch cords) used to
513 connect cables
- 514 **3.1.22**
515 **equipment cord**
516 cord connecting equipment to a distributor
- 517 **3.1.23**
518 **equipment interface**
519 point at which application-specific equipment can be connected to the generic cabling
- 520 **3.1.24**
521 **equipment room**
522 room dedicated for housing distributors and application-specific equipment
- 523 **3.1.25**
524 **equipotential bonding**
525 provision of electric connections between conductive parts, intended to achieve equipotentiality
526 [195-01-10 of IEC 60050-195:1998]
- 527 **3.1.26**
528 **external network interface**
529 point of demarcation between external and private network
- 530 NOTE In many cases the external network interface is the point of connection between the network provider's facilities and the
531 customer premises cabling
- 532 **3.1.27**
533 **fixed horizontal cable**
534 cable connecting the floor distributor to either the telecommunications outlet or the consolidation point (if
535 present)
- 536 **3.1.28**
537 **floor distributor**
538 distributor used to make connections between the horizontal cable, other cabling subsystems and active
539 equipment (see telecommunications room)

- 540 **3.1.29**
541 **generic cabling**
542 structured telecommunications cabling system, capable of supporting a wide range of applications.
543 Application-specific hardware is not a part of generic cabling
- 544 NOTE Generic cabling can be installed without prior knowledge of the required applications.
- 545 **3.1.30**
546 **horizontal cable**
547 cable connecting the floor distributor to the telecommunications outlet(s) or Consolidation Point(s)
- 548 **3.1.31**
549 **hybrid cable**
550 assembly of two or more different types or Categories of cables or cable units covered by an overall sheath. It
551 may be covered by an overall screen
- 552 **3.1.32**
553 **individual work area**
554 minimum building space which would be reserved for an occupant
- 555 **3.1.33**
556 **interconnect**
557 method of connecting a cabling subsystem to equipment (or another cabling subsystem) without the use of a
558 patch cord or jumper
- 559 **3.1.34**
560 **jumper**
561 cable, cable unit or cable element without connectors used to make a connection on a cross-connect
- 562 **3.1.35**
563 **keying**
564 mechanical feature of a connector system that guarantees correct orientation of a connection or prevents the
565 connection to a jack or optical fibre adapter of the same type intended for another purpose
- 566 **3.1.36**
567 **link**
568 transmission path between any two interfaces of generic cabling. It excludes equipment cords and work area
569 cords
- 570 **3.1.37**
571 **multi-unit cable**
572 balanced cable containing more than four pairs
- 573 **3.1.38**
574 **optical fibre cable (or optical cable)**
575 cable comprising one or more optical fibre cable elements
- 576 **3.1.39**
577 **optical fibre duplex adapter**
578 mechanical device designed to align and join two duplex connectors
- 579 **3.1.40**
580 **optical fibre duplex connector**
581 mechanical termination device designed to transfer optical power between two pairs of optical fibres

- 582 **3.1.41**
583 **pair**
584 twisted pair or one side circuit (two diametrically facing conductors) in a star quad
- 585 **3.1.42**
586 **patch cord**
587 cord used to establish connections on a patch panel
- 588 **3.1.43**
589 **patch panel**
590 cross-connect designed to accommodate the use of patch cords
- 591 NOTE It facilitates administration for moves and changes
- 592 **3.1.44**
593 **permanent link**
594 transmission path between two or – if a consolidation point is present in the cabling - three mated interfaces
595 of generic cabling, excluding equipment cords, work area cords and cross-connections, but including the
596 connecting hardware at each end
- 597 **3.1.45**
598 **screened cable**
599 assembly of two or more balanced twisted pair cable elements or one or more quad cable elements where
600 each element is individually screened and/or the elements are contained within an overall screen
- 601 **3.1.46**
602 **screened cabling**
603 system of telecommunications cables, cords and connecting hardware each of which contains screens and
604 within which the screens are interconnected
- 605 **3.1.47**
606 **small form factor connector**
607 optical fibre connector designed to accommodate two or more optical fibres with at least the same mounting
608 density as the connectors used for balanced cabling
- 609 **3.1.48**
610 **splice**
611 joining of conductors or fibres, generally from separate cables
- 612 **3.1.49**
613 **star quad**
614 cable element which comprises four insulated conductors twisted together. Two diametrically facing
615 conductors form a transmission pair
- 616 NOTE 1 Cables containing star quads can be used interchangeably with cables consisting of pairs, provided the electrical
617 characteristics meet the same specifications
- 618 NOTE 2 Often, the term quad is used instead of star quad
- 619 **3.1.50**
620 **telecommunications**
621 branch of technology concerned with the transmission, emission and reception of signs, signals, writing,
622 images and sounds; that is, information of any nature by cable, radio, optical or other electromagnetic
623 systems
- 624 NOTE The term telecommunications has no legal meaning when used in this document

- 625 **3.1.51**
626 **telecommunications room**
627 enclosed space for housing telecommunications equipment, cable terminations, and cross-connect cabling.
628 The telecommunications room is a recognized cross-connect point between the backbone and horizontal
629 cabling subsystems
- 630 **3.1.52**
631 **terminal equipment**
632 application-specific equipment located in the work area
- 633 **3.1.53**
634 **telecommunications outlet**
635 fixed connecting device where the horizontal cable terminates. The telecommunications outlet provides the
636 interface to the work area cabling
- 637 **3.1.54**
638 **test interface**
639 point at which test equipment can be connected to the generic cabling
- 640 **3.1.55**
641 **twisted pair**
642 cable element that consists of two insulated conductors twisted together in a determined fashion to form a
643 balanced transmission line
- 644 **3.1.56**
645 **unscreened cable**
646 balanced cable without any screens
- 647 **3.1.57**
648 **work area**
649 building space where the occupants interact with telecommunications terminal equipment
- 650 **3.1.58**
651 **work area cord**
652 cord connecting the telecommunications outlet to the terminal equipment
- 653 **3.2 Abbreviations**
- | | | |
|-----|----------|--|
| 654 | ACR | Attenuation to crosstalk ratio |
| 655 | ATM | Asynchronous transfer mode |
| 656 | BD | Building distributor |
| 657 | c | Velocity of propagation in free space |
| 658 | C | Connection |
| 659 | CC | Cross-connect |
| 660 | CD | Campus distributor |
| 661 | CP | Consolidation point |
| 662 | CSMA/CD | Carrier sense multiple access with collision detection |
| 663 | d.c. | Direct current |
| 664 | EI | Equipment interface |
| 665 | ELFEXT | Equal level far end crosstalk loss |
| 666 | EMC | Electromagnetic compatibility |
| 667 | EQP | Equipment |

668	FD	Floor distributor
669	FDDI	Fibre distributed data interface
670	FEXT	Far-end crosstalk loss
671	ffs	For further study
672	FOIRL	Fibre optic inter-repeater link
673	IDC	Insulation displacement connection
674	IPC	Insulation piercing connection
675	ISDN	Integrated services digital network
676	IT	Information technology
677	LAN	Local area network
678	LCL	Longitudinal conversion loss
679	LCTL	Longitudinal conversion transfer loss
680	MUTO	Multi-user telecommunications outlet
681	N/A	Not applicable
682	NEXT	Near-end crosstalk loss
683	OE EQP	Opto-electronic equipment
684	PBX	Private branch exchange
685	PC	Physical contact
686	PMD	Physical Layer Medium Dependent
687	PP	Patch panel
688	PSACR	Power sum attenuation to crosstalk ratio
689	PSFEXT	Power sum far-end crosstalk loss
690	PSELFEXT	Power sum equal level far end crosstalk loss
691	PSNEXT	Power sum near-end crosstalk loss
692	S	Splice
693	SC	Subscriber connector
694	SC-D	Duplex SC connector
695	TCL	Transfer conversion loss
696	TE	Terminal equipment
697	TI	Test interface
698	TO	Telecommunications outlet
699	TP-PMD	Twisted Pair Physical Layer Medium Dependent

700 **4 Structure of the generic cabling system**

701 **4.1 General**

702 This Clause identifies the functional elements of generic cabling, describes how they are connected together
703 to form subsystems and identifies the interfaces at which application-specific components are connected by
704 the generic cabling. Channels, created by connecting application-specific cabling components to the generic
705 cabling, are used to support applications.

706 **4.2 Functional elements**

707 The functional elements of generic cabling are as follows:

- 708 a) campus distributor (CD);
- 709 b) campus backbone cable;
- 710 c) building distributor (BD);
- 711 d) building backbone cable;
- 712 e) floor distributor (FD);
- 713 f) horizontal cable;
- 714 g) consolidation point (CP);
- 715 h) consolidation point cable (CP cable);
- 716 i) multi-user TO assembly;
- 717 j) telecommunications outlet (TO).

718 Groups of these functional elements are connected together to form cabling subsystems.

719 **4.3 General structure and hierarchy**

720 Generic cabling systems contain three cabling subsystems: campus backbone, building backbone and horizontal cabling. The cabling subsystems are connected together to create a generic cabling system with a structure as shown in Figure 2. The composition of the subsystems is described in 4.4.1, 4.4.2 and 4.4.3. The functional elements of the cabling subsystems are interconnected to form a basic hierarchical topology as shown in Figure 3. Where the functions of distributors are combined (see 4.7.1) the intermediate cabling subsystem(s) are not required.

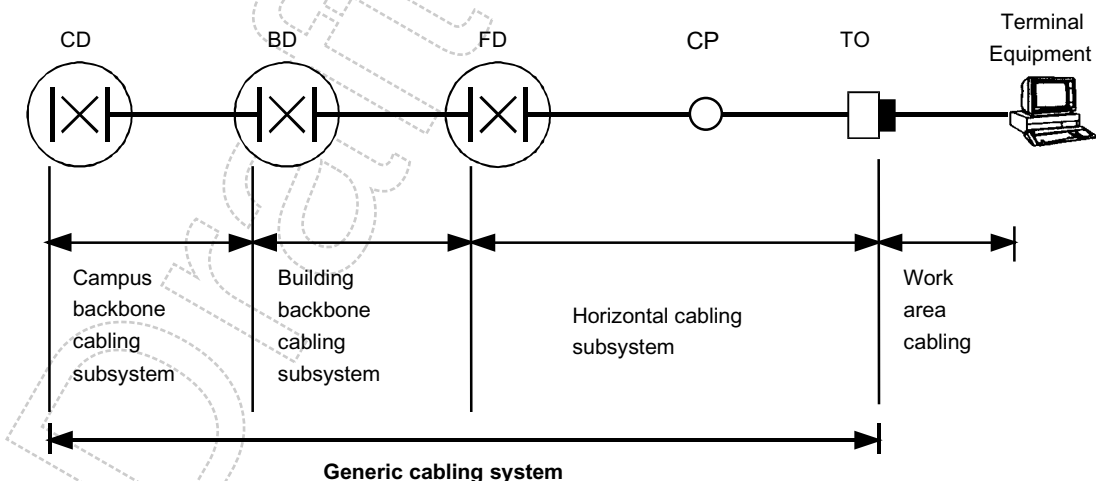

726

727

Figure 2 - Structure of generic cabling

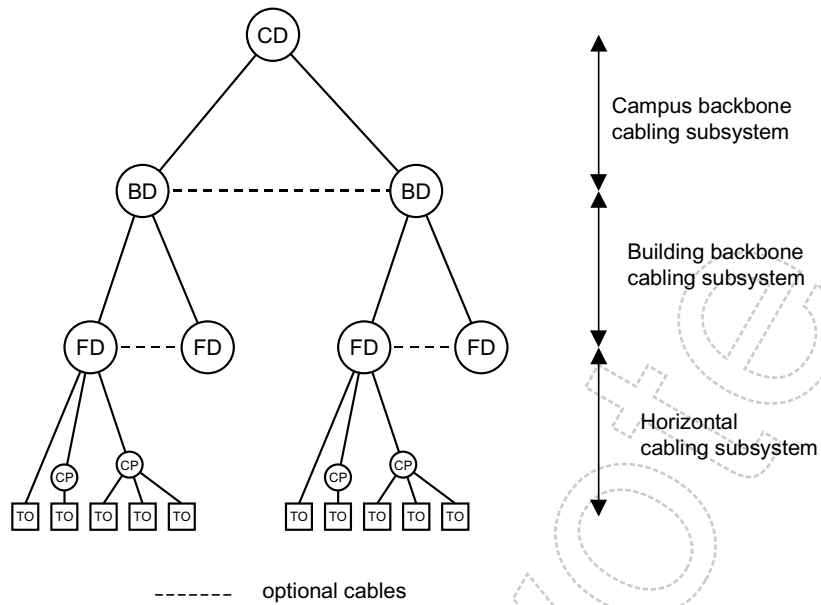

728

Figure 3 – Hierarchical structure of generic cabling

729 Connections between cabling subsystems are either active, requiring application-specific equipment, or passive.
 730 Connection to application-specific equipment adopts either an interconnect or a cross-connect approach (see
 731 Figure 6). Passive connections between cabling subsystems adopt either a cross-connect approach, by way of
 732 either patch cords or jumpers, or an interconnect approach.

733 Centralized cabling structures as shown in Figure 4 combine backbone and horizontal channels. The channels
 734 are provided by passive connections in the distributors. The connections are achieved by using either cross-
 735 connections or interconnections. In addition, for centralised optical fibre cabling, it is possible to create
 736 connections at the distributors using splices although this reduces the ability of the cabling to support re-con-
 737 figuration.

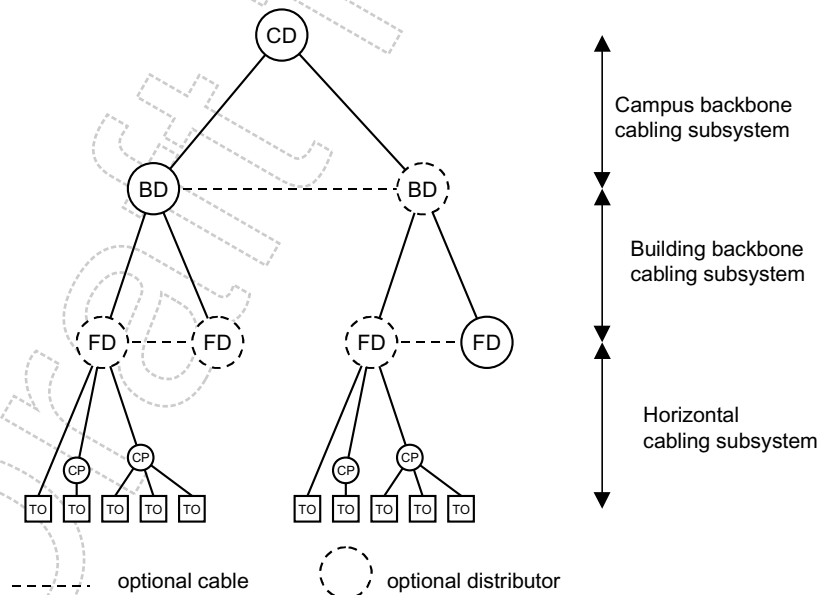

738

Figure 4 – Structures for centralized generic cabling

739

740 **4.4 Cabling subsystems**

741 **4.4.1 Campus backbone cabling subsystem**

742 The campus backbone cabling subsystem extends from the campus distributor to the building distributor(s)
743 usually located in separate buildings. When present, the subsystem includes:

- 744 a) the campus backbone cables including any cabling components within the building entrance facilities;
- 745 b) the mechanical termination of the campus backbone cables including the connections (e.g. of the
746 interconnect or cross-connect) at both the campus and building distributors together with associated
747 patch cords and/or jumpers at the CD.

748 Although equipment cords are used to connect the transmission equipment to the cabling subsystem, they
749 are not considered part of the cabling subsystem because they are application-specific. Where the building
750 distributor does not exist, the campus backbone cabling subsystem extends from the campus distributor to
751 the floor distributor.

752 The campus backbone cabling may provide direct connection between building distributors. When provided
753 this cabling shall be in addition to that required for the basic hierarchical topology.

754 **4.4.2 Building backbone cabling subsystem**

755 A building backbone cabling subsystem extends from building distributor(s) to the floor distributor(s). When
756 present, the subsystem includes:

- 757 a) the building backbone cables;
- 758 b) the mechanical termination of the building backbone cables including the connections (e.g. of the
759 interconnect or cross-connect) at both the building and floor distributors together with associated patch
760 cords and/or jumpers at the BD;

761 Although equipment cords are used to connect the transmission equipment to the cabling subsystem, they
762 are not considered part of the cabling subsystem because they are application-specific.

763 The building backbone cabling may provide direct connection between floor distributors. When provided this
764 cabling shall be for back-up and in addition to those required for the basic hierarchical topology.

765 **4.4.3 Horizontal cabling subsystem**

766 The horizontal cabling subsystem extends from a floor distributor to the telecommunications outlet(s) con-
767 nected to it. The subsystem includes:

- 768 a) the horizontal cables;
- 769 b) the mechanical termination of the horizontal cables including the connections (e.g. of the interconnect or
770 cross-connect) at the telecommunications outlet and the floor distributor together with associated patch
771 cords and/or jumpers at the FD;
- 772 c) a consolidation point (optional);
- 773 d) the telecommunications outlets.

774 Although work area and equipment cords are used to connect terminal and transmission equipment,
775 respectively, to the cabling subsystem, they are not considered part of the cabling subsystem because they
776 are application-specific. Horizontal cables shall be continuous from the floor distributor to the telecommuni-
777 cations outlets unless a consolidation point is installed (see 4.7.6).

778 4.4.4 Design objectives

779 Horizontal cabling should be designed to support the broadest set of existing and emerging applications and
780 therefore provide the longest operational life. This will minimize disruption and the high cost of recabling in
781 the work area.

782 It is generally not possible or economically viable to install backbone cabling for the entire life of the generic
783 cabling system. Instead, the design may be based on current or foreseeable application requirements. Such
784 short-term selection criteria are often appropriate for building backbone cabling where there is good physical
785 access to pathways for future changes.

786 The selection of campus backbone cabling may require a longer term approach than that adopted for the
787 building backbone, particularly if access to pathways is more limited.

788 4.5 Accommodation of functional elements

789 Figure 5 shows an example of how the functional elements are accommodated in a building.

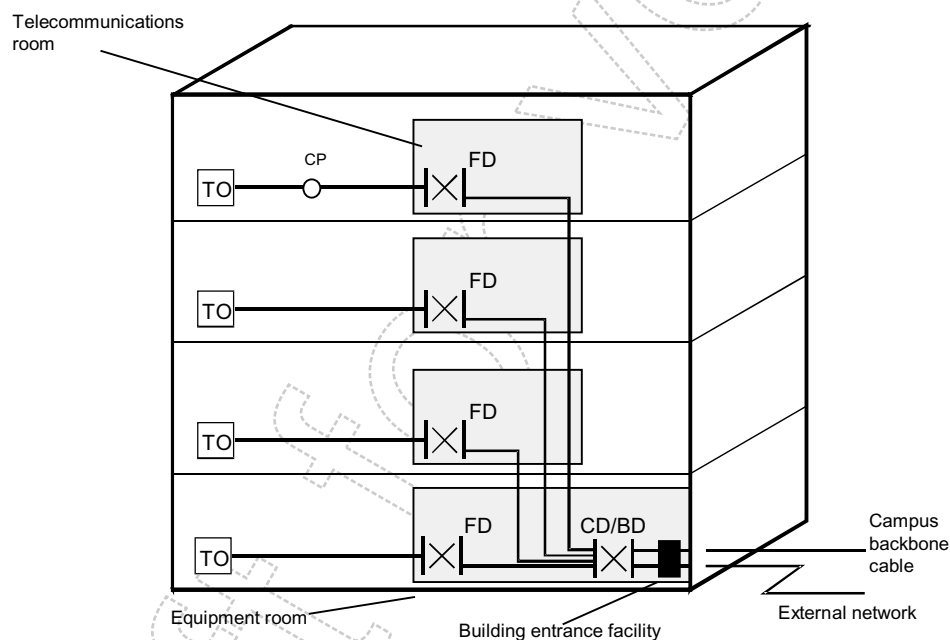

790

791

Figure 5 - Accommodation of functional elements

792 Distributors are typically located in equipment rooms or telecommunications rooms. The requirements for the
793 accommodation of distributors are specified in EN 50174-1.

794 Cables are routed using pathways. A variety of cable management systems can be used to support the cables
795 within the pathways including ducts, conduits and tray. Requirements for the pathways and the cable management
796 systems within them are provided in the EN 50174 series.

797 Telecommunications outlets are located in the work area, depending on the design of the building.

798 4.6 Interfaces

799 4.6.1 Equipment interfaces and test interfaces

800 Equipment interfaces to generic cabling are located at the ends of each subsystem.

801

802 Any distributor may have an equipment interface to an external service at any port, and may use either
 803 interconnects or cross-connects (see Figure 6). A consolidation point does not provide an equipment
 804 interface to the generic cabling system. Figure 7 shows the potential equipment interfaces to the horizontal
 805 and backbone cabling subsystems.

806 Test interfaces to generic cabling are located at the ends of each subsystem and at consolidation points,
 807 where present. Figure 7 shows the potential test interfaces to the horizontal and backbone
 808 subsystems.

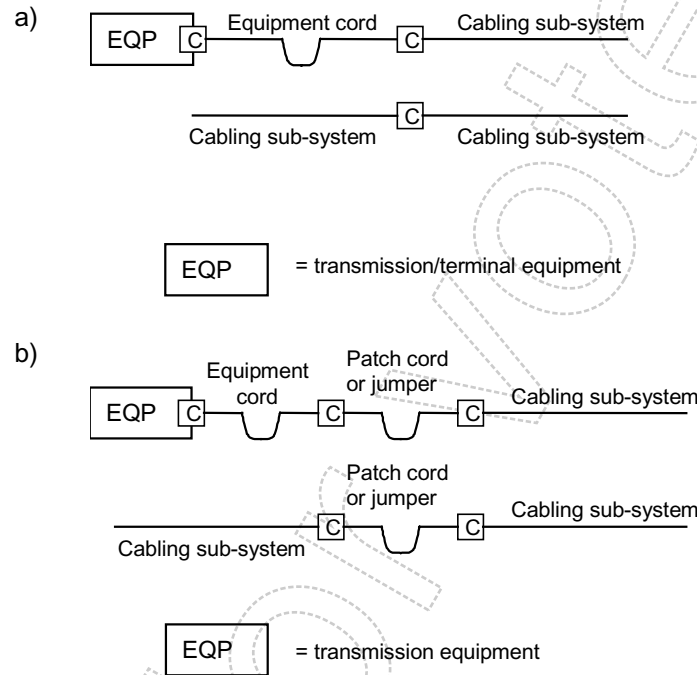

Figure 6- Interconnect and cross-connect models
 a) interconnect model
 b) crossconnect model

809
 810
 811

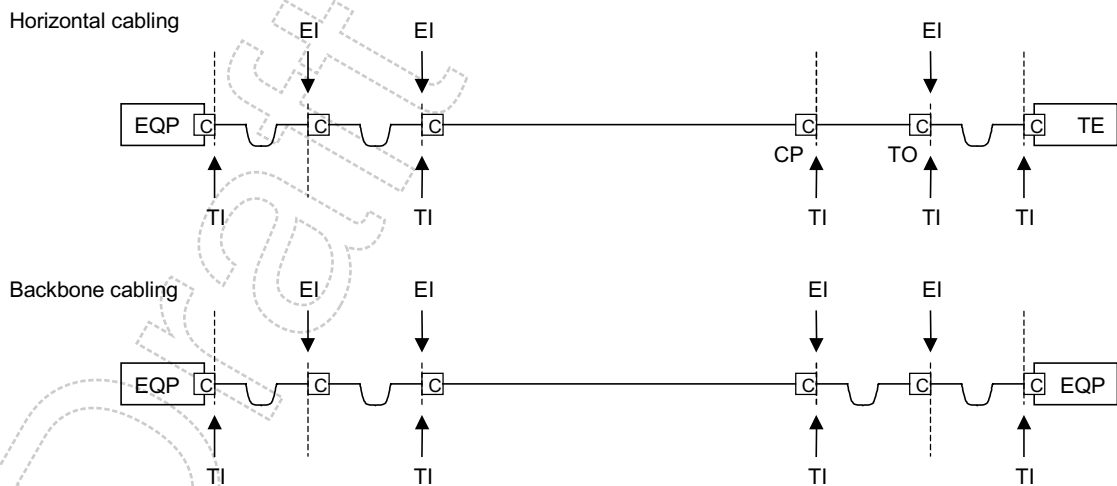

Figure 7 - Test and equipment interfaces

812
 813

814 **4.6.2 Channels and links**

815 The transmission performance of generic cabling between specific test interfaces is detailed in Clause 5 in
 816 terms of the channel and Annex A for links.

817 The channel is the transmission path between IT equipment such as a LAN hub (EQP in Figure 6) and the
 818 terminal equipment. A typical channel would consist of the horizontal subsystem together with work area and
 819 equipment cords. For longer reach services the channel would be formed by the connection of two or more
 820 subsystems (including work area cords and/or equipment cords). It is important that the generic cabling
 821 channel is designed to meet the required class of performance for the applications that are to be run. For the
 822 purposes of testing, the channel excludes the connections at the application-specific equipment.

823 A link is the transmission path between two test interfaces. Links may be tested either during commissioning
 824 or for the detection of faults that are suspected in the cabling. The link includes the connections at the ends of
 825 the cabling link under test.

826 4.6.3 External network interface

827 Connections to external networks for the provision of services (e.g. public telecommunications) are made at
 828 external network interfaces. The location of external network interfaces, if present, and the facilities which
 829 shall be provided may be regulated by national, regional, and local regulations. If the external network
 830 interface is not connected directly to a generic cabling interface the performance of the cabling between the
 831 external network interface and the generic cabling interface should be taken into account and should be
 832 considered as part of the initial design and implementation of customer applications. The type of cross-
 833 connect and the cable may be governed by national regulations, which then shall be considered in planning
 834 the generic cabling.

835 4.7 Dimensioning and configuring

836 4.7.1 Distributors

837 The number and type of subsystems that are included in a generic cabling implementation depends upon the
 838 geography and size of the campus or building, and upon the strategy of the user. Usually there would be one
 839 campus distributor per campus, one building distributor per building, and one floor distributor per floor. If the
 840 premises comprise only a single building which is small enough to be served by a single building distributor,
 841 there is no need for a campus backbone cabling subsystem. Similarly larger buildings may be served by
 842 multiple building distributors interconnected via a campus distributor.

843 The design of the floor distributor shall ensure that the lengths of patch cords, jumpers and equipment cords
 844 are minimised and administration should ensure that the design lengths are maintained during operation.

845 Distributors should be located such that the resulting cable lengths are consistent with the channel
 846 performance requirements of Clause 5. For the implementations described in Clause 6, using the
 847 components of Clauses 7, 8 and 9, the maximum channel lengths in Table 1 shall be observed. In the case of
 848 the reference implementations described in Clause 6, distributors shall be located to ensure that the channel
 849 lengths in Table 1 are not exceeded.

850 However, not all applications are supported over the maximum lengths shown in Table 1 using a single cable
 851 type. Table 22, Table 23 and Table 24 in Clause 6 indicate that the support of specific applications over
 852 installed channels may require a mix of cabling media and performance specifications.

853 **Table 1 - Maximum channel lengths for reference implementations**

Channel	Length m
Horizontal	100
Horizontal + building backbone + campus backbone	2 000
NOTE In some implementations of the horizontal cabling subsystem in Clause 5, the FD may not support TOs up to the maximum distance shown.	

854 There should be a minimum of one floor distributor for every 1 000 m² of floor space reserved for offices. A
 855 minimum of one floor distributor should be provided for every floor. If a floor is sparsely populated (e.g. a
 856 lobby), it is permissible to serve this floor from the floor distributor located on an adjacent floor.

857 If a floor area extends beyond 1 000 m², additional floor distributors may need to be installed to more
858 effectively service the work area.

859 The functions of multiple distributors may be combined.

860 Figure 8 shows an example of generic cabling. The building in the foreground shows each distributor housed
861 separately. The building in the background shows that the functions of a floor distributor and the building
862 distributor have been combined into a single distributor.

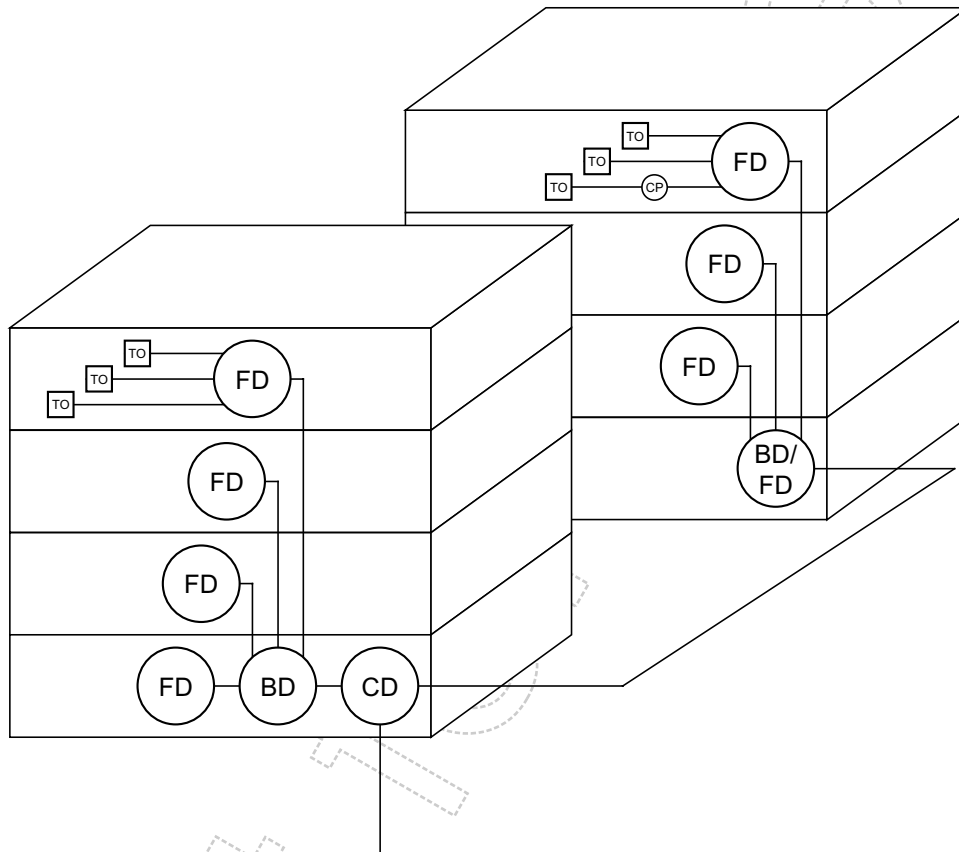

863

864

Figure 8 - Example of a generic cabling system with combined BD and FD

865 In certain circumstances, for example for security or reliability reasons, redundancy may be built into a cab-
866 ling design. Figure 9 is a schematic showing one of many possible examples of the connection of functional
867 elements within the structured framework to provide such protection against failure in one or more parts of the
868 cabling infrastructure. This might form the basis for the design of generic cabling for a building, providing
869 some protection against such hazards as fire damage or the failure of the external network feeder cable.

870 **4.7.2 Cables**

871 Cable types used in the reference implementations of Clause 6 are given in Clause 7. Hardware for
872 connecting cables shall only provide direct onward attachment for each conductor and shall not provide any
873 contact between more than one incoming or outgoing conductor (e.g. bridge taps shall not be used).

874 **4.7.3 Work area cords and equipment cords**

875 The work area cord connects the telecommunications outlet to the terminal equipment. Equipment cords
876 connect transmission equipment to the generic cabling at distributors. Both are non-permanent and can be
877 application-specific. Assumptions have been made concerning the length and the transmission performance
878 of these cords; the assumptions are identified when relevant.

879 The performance contribution of these cords shall be taken into account in the design of the channel. Clause 6
880 provides guidance on cord lengths for reference implementations of generic cabling.

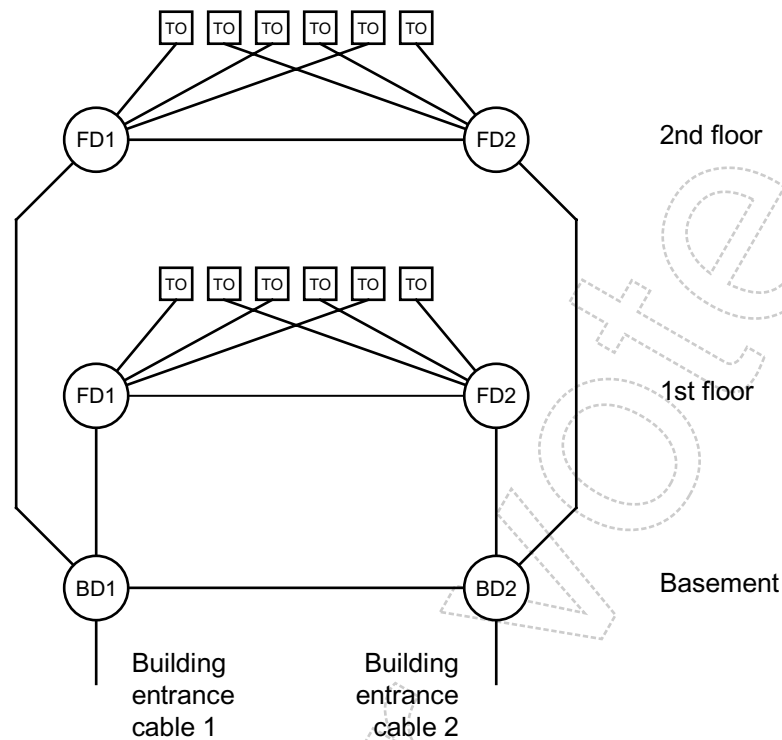

881 **Figure 9 - Connection of functional elements providing redundancy**

882 4.7.4 Patch cords and jumpers

883 Patch cords and jumpers are used within cross-connect implementations at distributors. The performance
884 contribution of these cords shall be taken into account in the design of the channel. Clause 6 provides guidance
885 on cord/jumper lengths for reference implementations of generic cabling.

886 4.7.5 Telecommunications outlet (TO)

887 4.7.5.1 General requirements

888 The design of generic cabling should provide for telecommunications outlets to be installed throughout the
889 usable floor space. A high density of telecommunications outlets will enhance the ability of the cabling to
890 accommodate changes. Telecommunications outlets may be presented singly, or in groups.

- 891 a) each individual work area shall be served by a minimum of two TOs;
- 892 b) the first outlet should be for four pair balanced cable terminated in accordance with 8.2.5;
- 893 c) the second outlet may be for two optical fibres terminated in accordance with 8.3 or four pair balanced
894 cable terminated in accordance with 8.2.5 as required;
- 895 d) each telecommunications outlet shall have a permanent means of identification that is visible to the user;
- 896 e) devices such as baluns and impedance matching adapters, if used, shall be external to the outlet.

897 Two pairs per TO may be used as an alternative to four pairs, however this requires pair reassignment and
898 will not support some applications (see Annex E).

899 Care should be taken that the initial pair assignment and all subsequent changes are recorded (see
900 EN 50174-1 for details of recommended administration schemes). Pair reassignment by means of inserts is
901 allowed.

902 **4.7.5.2 Single user TO assembly**

903 In a general implementation of generic cabling, one assembly of TOs serves a single work area. In this case,
904 one of the implementation options shown in Figure 11 (for balanced cabling) and Figure 13 (for optical fibre
905 cabling) of Clause 6 shall be used and the assembly of TOs shall be known as a single user TO assembly.

906 Where the single user TO assembly is used

- 907 a) the TO assembly should be located in user-accessible locations;
- 908 b) the performance contribution of work area cords, patch cords, jumpers and equipment cords shall be
909 taken into account to ensure that the channel requirements of Clause 5 are met.

910 **4.7.5.3 Multi-user TO assembly**

911 In an open office environment, a single assembly of TOs may be used to serve more than one work area.
912 One of the implementation options shown in Figure 11 (for balanced cabling) and Figure 13 (for optical fibre
913 cabling) of Clause 6 shall be used and the assembly of TOs shall be known as a multi-user TO assembly.

914 In addition, where the multi-user TO assembly is used:

- 915 a) a multi-user TO assembly shall be located in an open work area so that each furniture cluster is served
916 by at least one multi-user TO assembly;
- 917 b) a multi-user TO assembly should be limited to serving a maximum of twelve work areas;
- 918 c) a multi-user TO assembly should be located in user accessible, permanent locations;
- 919 d) a multi-user TO assembly shall not be installed in ceiling spaces or any obstructed areas;
- 920 e) the performance contribution of work area cords, patch cords, jumpers and equipment cords shall be
921 taken into account to ensure that the channel requirements of Clause 5 are met;
- 922 f) the length of the work area cord should be limited to ensure cable management in the work area.

923 **4.7.6 Consolidation point**

924 The installation of a consolidation point in the horizontal cabling between the floor distributor and the
925 telecommunications outlet may be useful in an open office environment where the flexibility of relocating TOs
926 in the work area is required. One consolidation point is permitted between a FD and any TO. The consoli-
927 dation point shall only contain passive connections.

928 In addition, where a consolidation point is used:

- 929 a) the consolidation point shall be located so that each work area group is served by at least one
930 consolidation point;
- 931 b) the consolidation point should be limited to serving a maximum of twelve work areas;
- 932 c) a consolidation point should be located in accessible permanent locations such as ceiling voids and
933 under floors;

934 d) for balanced cabling, the effect of multiple connections in close proximity on transmission performance
935 should be taken into consideration when planning the cable lengths between the floor distributor and the
936 consolidation point;

937 e) a consolidation point has labelling and documentation requirements and shall be covered in the cabling
938 administration system.

939 **4.7.7 Telecommunications rooms and equipment rooms**

940 A telecommunications room should provide all the facilities (space, power, environmental control etc.) for
941 passive components, active devices, and public network interfaces housed within it. Each telecommuni-
942 cations room should have direct access to the backbone.

943 An equipment room is an area within a building where telecommunications equipment is housed and may or
944 may not contain distributors. Equipment rooms are treated differently from telecommunications rooms
945 because of the nature or complexity of the equipment (e.g. PBXs or extensive computer installations). More
946 than one distributor may be located in an equipment room. If a telecommunications space houses more than
947 one distributor it should be considered an equipment room.

948 **4.7.8 Building entrance facilities**

949 Building entrance facilities are required whenever campus backbone, public and private network cables
950 (including antennae) enter buildings and a transition is made to internal cables. It comprises an entrance
951 point at a building wall and the pathway leading to the campus or building distributor. Local regulations may
952 require special facilities where the external cables are terminated. At this termination point, a change from
953 external to internal cable can take place.

954 **4.8 Electromagnetic compatibility**

955 Premises cabling is a passive system and cannot be tested for EMC compliance individually. Application-
956 specific equipment which is designed for one or more media is required to meet relevant EMC standards on
957 those media. Care should be taken that the installation of any of those media in a cabling system does not
958 degrade the characteristics of the system. The installation methods of EN 50174 series should be used to
959 minimise the effect of electromagnetic disturbances.

960 **4.9 Earthing and equipotential bonding**

961 EN 50174 and EN 50310 specify requirements for earthing and equipotential bonding.

962 **5 Channel performance**

963 **5.1 General**

964 This Clause specifies the minimum channel performance of generic cabling. The performance of the cabling
965 is specified for individual channels for two different media types (balanced cable and optical fibre). The
966 channel performance specifications for balanced cabling are separated into Classes that allow for the
967 transmission of the applications in Annex E. In the case of cable sharing, additional requirements shall be
968 taken into account for balanced cabling. The additional crosstalk requirements are specified in 7.3.

969 The channel performance requirements described in this Clause shall be used for the design and may be
970 used for verification of any implementation of this European standard. Where required the test methods
971 defined or referenced by this Clause shall apply. In addition, these requirements can be used for application
972 development and troubleshooting. The channel performance specification of the relevant Class shall be met
973 for all temperatures at which the cabling is intended to operate. Consideration should be given to measuring
974 performance at worst case temperatures, or calculating worst case performance based on measurements
975 made at other temperatures.

976 The channel specifications in this Clause allow for the transmission of defined Classes of applications over
977 distances other than those of Clause 6, and/or using media and components with different transmission
978 performance than those of Clauses 7, 8 and 9.

979 Link performance requirements are specified in Annex A.

980 5.2 Layout of channels

981 The performance of a channel is specified at and between connections to active equipment. The channel
982 comprises only passive sections of cable, connections, work area cords, equipment cords, patch cords and
983 jumpers. The performance contribution of active equipment connections is not taken into account.

984 Application support depends on channel performance only, which in turn depends on cable length, number of
985 connections, the performance of the components and the installation practices used.

986 Channels are implemented using:

- 987 – horizontal cabling only;
- 988 – building backbone cabling only;
- 989 – campus backbone cabling only;
- 990 – combinations of the above.

991 Equivalent channel performance can be achieved over greater lengths by the use of fewer connections or by
992 using components with higher performance.

993 Figure 10 shows an example of terminal equipment in the work area connected to transmission equipment
994 using two channels, an optical fibre channel and a balanced cabling channel. The optical fibre and balanced
995 cabling channels are connected together using an optical fibre to balanced copper cable converter. There are
996 four channel interfaces; one at each end of the balanced channel, and one at each end of the optical fibre
997 channel.

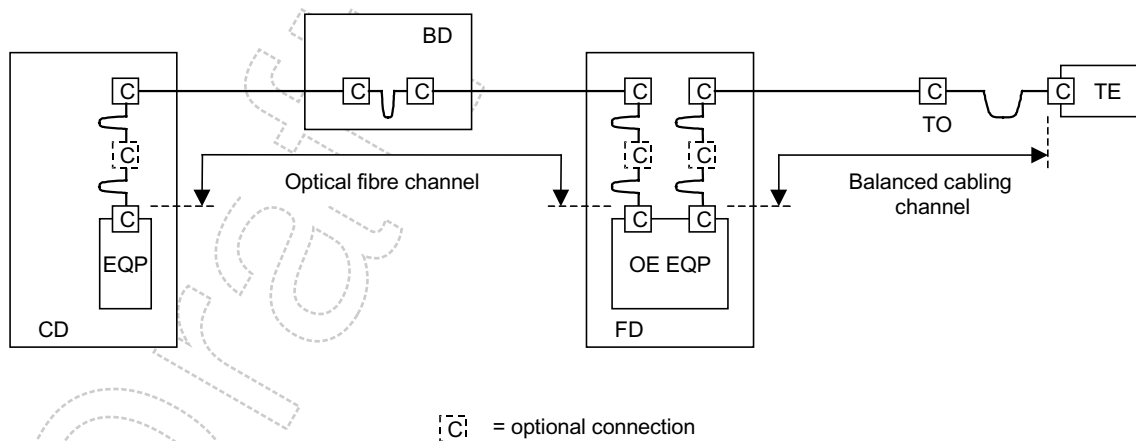

998

999

Figure 10 - Example of a system showing the location of cabling interfaces

1000 **5.3 Classification of balanced cabling channels**

1001 This standard specifies the following classes for balanced cabling.

1002 Class A is specified up to 100 kHz.

1003 Class B is specified up to 1 MHz.

1004 Class C is specified up to 16 MHz.

1005 Class D is specified up to 100 MHz.

1006 Class E is specified up to 250 MHz.

1007 Class F is specified up to 600 MHz.

1008 A Class A channel is specified so that it will provide the minimum transmission performance to support Class
1009 A applications. Similarly, Class B, C, D, E and F channels provide the transmission performance to support
1010 Class B, C, D, E and F applications respectively. Channels of a given class will support all applications of a
1011 lower class. Class A is regarded as the lowest class.

1012 Horizontal cabling shall be installed to provide a minimum of Class D performance. Annex E lists known
1013 applications by class.

1014 **5.4 Balanced cabling channel performance**

1015 **5.4.1 General**

1016 The parameters specified in this subclause apply to channels with screened or unscreened cable elements,
1017 with or without an overall screen, unless explicitly stated otherwise.

1018 The nominal impedance of channels is 100 Ω . This is achieved by suitable design, and appropriate choice of
1019 cabling components (irrespective of their nominal impedance).

1020 NOTE The term "attenuation" is used in 5.4.3, 5.4.4, 5.4.5, 5.4.6, 5.4.7, 5.4.12 and 5.4.13 since it is common usage within the cabling
1021 industry. However, the correct term is insertion loss which includes the effect of impedance variations both with and between the cabling
1022 components in the channel.

1023 **5.4.2 Return loss**

1024 The variation of the input impedance of a channel is characterised by the return loss. The return loss
1025 parameter is applicable to Classes C, D, E and F only. The return loss for each pair of a channel shall meet
1026 the limits computed, to one decimal place, using the formulae of Table 2. The limits shown in Table 3 are
1027 derived from the formulae at key frequencies only.

1028 When required, the return loss shall be measured according to EN 50346. Terminations of 100 Ω shall be
1029 connected to the cabling elements under test at the remote end of the channel. The return loss requirements
1030 shall be met at both ends of the cabling.

1031

Table 2 - Formulae for return loss limits for a channel

Class	Frequency MHz	Minimum return loss dB
C	$1 \leq f \leq 16$	15,0
D	$1 \leq f < 20$	17,0
	$20 \leq f \leq 100$	$30-10\log(f)$
E	$1 \leq f < 10$	19,0
	$10 \leq f < 40$	$24-5\log(f)$
	$40 \leq f \leq 250$	$32-10\log(f)$
F	$1 \leq f < 10$	19,0
	$10 \leq f < 40$	$24-5\log(f)$
	$40 \leq f < 251,2$	$32-10\log(f)$
	$251,2 \leq f \leq 600$	8,0

1032

1033

Table 3 - Return loss limits for a channel at key frequencies

Frequency MHz	Minimum return loss dB			
	Class C	Class D	Class E	Class F
1,0	15,0	17,0	19,0	19,0
16,0	15,0	17,0	18,0	18,0
100,0	N/A	10,0	12,0	12,0
250,0	N/A	N/A	8,0	8,0
600,0	N/A	N/A	N/A	8,0

1034 Values of return loss at frequencies for which the measured channel attenuation is below 3,0 dB are for
1035 information only.

1036 **5.4.3 Attenuation / Insertion loss**

1037 The attenuation α for each pair of a channel measured as insertion loss shall not exceed the limits computed,
1038 to one decimal place, using the formulae of Table 4. The limits shown in Table 5 are derived from the
1039 formulae at key frequencies only.

1040 When required, the attenuation of the channel shall be measured according to EN 50346.

1041

Table 4 - Formulae for attenuation limits for a channel

Class	Frequency MHz	Maximum attenuation dB
A	$f = 0,1$	16,0
B	$f = 0,1$	5,5
	$f = 1$	5,8
C	$1 \leq f \leq 16$	$1,05 \cdot (3,23\sqrt{f}) + 4 \cdot 0,2$
D	$1 \leq f \leq 100$	$1,05 \cdot (1,9108\sqrt{f} + 0,0222 \cdot f + 0,2/\sqrt{f}) + 4 \cdot 0,04 \cdot \sqrt{f}$, 4,0 min
E	$1 \leq f \leq 250$	$1,05 \cdot (1,82\sqrt{f} + 0,0169 \cdot f + 0,25/\sqrt{f}) + 4 \cdot 0,02 \cdot \sqrt{f}$, 4,0 min
F	$1 \leq f \leq 600$	$1,05 \cdot (1,8\sqrt{f} + 0,01 \cdot f + 0,2/\sqrt{f}) + 4 \cdot 0,02 \cdot \sqrt{f}$, 4,0 min

1042

1043

Table 5 - Attenuation limits for a channel at key frequencies

Frequency MHz	Maximum attenuation dB					
	Class A	Class B	Class C	Class D	Class E	Class F
0,1	16,0	5,5	N/A	N/A	N/A	N/A
1,0	N/A	5,8	4,2	4,0	4,0	4,0
16,0	N/A	N/A	14,4	9,1	8,3	8,1
100,0	N/A	N/A	N/A	24,0	21,7	20,8
250,0	N/A	N/A	N/A	N/A	35,9	33,8
600,0	N/A	N/A	N/A	N/A	N/A	54,6

1044

1045 5.4.4 Near-end crosstalk loss (NEXT)

1046 5.4.4.1 Pair-to-pair NEXT

1047 The pair-to-pair NEXT α_{NEXT} between each pair combination of a channel shall meet the limits computed, to
 1048 one decimal place, using the formulae of Table 6. The limits shown in Table 7 are derived from the formulae
 1049 at key frequencies only.

1050 When required, the NEXT shall be measured according to EN 50346. The NEXT requirements shall be met at
 1051 both ends of the cabling.

1052

Table 6 - Formulae for NEXT limits for a channel

Class	Frequency MHz	Minimum NEXT dB
A	$f = 0,1$	27,0
B	$0,1 \leq f \leq 1$	$25,0 - 15 \cdot \log(f)$
C	$1 \leq f \leq 16$	$39,1 - 16,4 \cdot \log(f)$
D	$1 \leq f \leq 100$	$-20 \log \left(\frac{65,3 - 15 \log(f)}{10^{-20}} + 2 \cdot \frac{83 - 20 \log(f)}{10^{-20}} \right)$, 60,0 max.
E	$1 \leq f \leq 250$	$-20 \log \left(\frac{74,3 - 15 \log(f)}{10^{-20}} + 2 \cdot \frac{94 - 20 \log(f)}{10^{-20}} \right)$, 65,0 max
F	$1 \leq f \leq 600$	$-20 \log \left(\frac{102,4 - 15 \log(f)}{10^{-20}} + 2 \cdot \frac{102,4 - 15 \log(f)}{10^{-20}} \right)$, 65,0 max.

1053

1054

Table 7 - NEXT limits for a channel at key frequencies

Frequency MHz	Minimum NEXT dB					
	Class A	Class B	Class C	Class D	Class E	Class F
0,1	27,0	40,0	N/A	N/A	N/A	N/A
1,0	N/A	25,0	39,1	60,0	65,0	65,0
16,0	N/A	N/A	19,4	43,6	53,2	65,0
100,0	N/A	N/A	N/A	30,1	39,9	62,9
250,0	N/A	N/A	N/A	N/A	33,1	56,9
600,0	N/A	N/A	N/A	N/A	N/A	51,2

1055

1056 Values of NEXT at frequencies for which the measured channel attenuation is below 4,0 dB are for
1057 information only.

1058 **5.4.4.2 Power Sum NEXT (PSNEXT)**

1059 The PSNEXT parameter is applicable to Classes D, E and F only. The PSNEXT for each pair of a channel
1060 shall meet the limits computed, to one decimal place, using the formulae of Table 8. The limits shown in
1061 Table 9 are derived from the formulae at key frequencies only.

1062 The PSNEXT requirements shall be met at both ends of the cabling.

1063 PSNEXT of pair k , $\alpha_{PSNEXT}(k)$, is computed from pair-to-pair NEXT $\alpha_{NEXT}(i,k)$ of the adjacent pairs i , $i = 1 \dots n$, as
1064 follows:

1065
$$\alpha_{PSNEXT}(k) = -10 \log \sum_{i=1, i \neq k}^n 10^{-0,1 \alpha_{NEXT}(i,k)} \quad (1)$$

1066 where $\alpha_{NEXT}(i,k)$ is the pair-to-pair NEXT of pair k to adjacent pair i in dB

1067

Table 8 - Formulae for PSNEXT limits for a channel

Class	Frequency MHz	Minimum PSNEXT dB
D	$1 \leq f \leq 100$	$-20 \log \left(10^{\frac{62,3 - 15 \log(f)}{-20}} + 2 \cdot 10^{\frac{80 - 20 \log(f)}{-20}} \right), 57,0 \text{ max.}$
E	$1 \leq f \leq 250$	$-20 \log \left(10^{\frac{72,3 - 15 \log(f)}{-20}} + 2 \cdot 10^{\frac{90 - 20 \log(f)}{-20}} \right), 62,0 \text{ max}$
F	$1 \leq f \leq 600$	$-20 \log \left(10^{\frac{99,4 - 15 \log(f)}{-20}} + 2 \cdot 10^{\frac{99,4 - 15 \log(f)}{-20}} \right), 62,0 \text{ max.}$

1068

1069

Table 9 - PSNEXT limits for a channel at key frequencies

Frequency MHz	Minimum PSNEXT dB		
	Class D	Class E	Class F
0,1	N/A	N/A	N/A
1,0	57,0	62,0	62,0
16,0	40,6	50,6	62,0
100,0	27,1	37,1	59,9
250,0	N/A	30,2	53,9
600,0	N/A	N/A	48,2

1070 Values of PSNEXT at frequencies for which the measured channel attenuation is below 4,0 dB are for
1071 information only.

1072 5.4.5 Attenuation to crosstalk loss ratio (ACR)

1073 5.4.5.1 Pair-to-pair ACR

1074 ACR of pairs i and k , $\alpha_{ACR}(i,k)$, is computed from pair-to-pair NEXT $\alpha_{NEXT}(i,k)$ and attenuation $\alpha(i)$ of pair i as
1075 follows:

$$1076 \alpha_{ACR}(i,k) = \alpha_{NEXT}(i,k) - \alpha(i) \quad (2)$$

1077 where $\alpha_{NEXT}(i,k)$ is the pair-to-pair NEXT of pair k to adjacent pair i , in dB. The NEXT shall be measured
1078 according to EN 50346 in dB.

1079 $\alpha(i)$ is the attenuation of pair i , when measured according to EN 50346, in dB.

1080 The ACR for each pair combination of a channel shall meet the limits computed according to equation (2), to
1081 one decimal place, using the relevant formulae of Tables 4 and 6. The limits shown in Table 10 are derived
1082 with equation (2) at key frequencies only.

1083 The ACR requirements shall be met at both ends of the cabling.

1084

Table 10 - ACR limits for a channel at key frequencies

Frequency MHz	Minimum ACR dB		
	Class D	Class E	Class F
0,1	N/A	N/A	N/A
1,0	56,0	61,0	61,0
16,0	34,5	44,9	56,9
100,0	6,1	18,2	42,1
250,0	N/A	-2,8	23,1
600,0	N/A	N/A	-3,4

1085

5.4.5.2 Power sum ACR (PSACR)

1087 PSACR of pair k , $\alpha_{PSACR}(k)$, is computed from PSNEXT $\alpha_{PSNEXT}(k)$ and attenuation $\alpha(k)$ of pair k as follows:

1088
$$\alpha_{PSACR}(k) = \alpha_{PSNEXT}(k) - \alpha(k) \tag{3}$$

1089 where $\alpha_{PSNEXT}(k)$ is the PSNEXT of pair k in dB

1090 $\alpha(k)$ is the attenuation of pair k in dB when measured according to EN 50346.

1091 The PSACR parameter is applicable to Classes D, E and F only. The PSACR for each pair of a channel shall
 1092 meet the limits computed according to equation (3), to one decimal place, using the relevant formulae of
 1093 Tables 4 and 8. The limits shown in Table 11 are derived with equation (3) at key frequencies only.

1094 The PSACR requirements shall be met at both ends of the cabling.

1095

Table 11 - PSACR limits for a channel at key frequencies

Frequency MHz	Minimum PSACR dB		
	Class D	Class E	Class F
0,1	N/A	N/A	N/A
1,0	53,0	58,0	58,0
16,0	31,5	42,3	53,9
100,0	3,1	15,4	39,1
250,0	N/A	-5,8	20,1
600,0	N/A	N/A	-6,4

1096

5.4.6 ELFEXT

5.4.6.1 Pair-to-pair ELFEXT

1099 The ELFEXT parameter is applicable to Classes D, E and F only.

1100

1101 ELFEXT of pairs i and k , $\alpha_{ELFEXT}(i,k)$, is computed from pair-to-pair FEXT $\alpha_{FEXT}(i,k)$ and attenuation $\alpha(k)$ of
 1102 pair k as follows:

$$1103 \quad \alpha_{ELFEXT}(i,k) = \alpha_{FEXT}(i,k) - \alpha(k) \quad (4)$$

1104 where i is the number of the disturbed pair.

1105 k is the number of the disturbing pair.

1106 $\alpha_{FEXT}(i,k)$ is the pair-to-pair FEXT of pair k to adjacent pair i in dB. The FEXT shall be measured
 1107 according to EN 50346 in dB.

1108 $\alpha(k)$ is the attenuation of pair k in dB when measured according to EN 50346.

1109 The ELFEXT for each pair combination of a channel shall meet the limits computed, to one decimal place,
 1110 using the formulae of Table 12. The limits shown in Table 13 are derived from the formulae at key
 1111 frequencies only.

1112 **Table 12 - Formulae for ELFEXT limits for a channel**

Class	Frequency MHz	Minimum ELFEXT dB
D	$1 \leq f \leq 100$	$-20 \log \left(10^{\frac{63,8 - 20 \log(f)}{-20}} + 4 \cdot 10^{\frac{75,1 - 20 \log(f)}{-20}} \right)$
E	$1 \leq f \leq 250$	$-20 \log \left(10^{\frac{67,8 - 20 \log(f)}{-20}} + 4 \cdot 10^{\frac{83,1 - 20 \log(f)}{-20}} \right)$
F	$1 \leq f \leq 600$	$-20 \log \left(10^{\frac{94 - 20 \log(f)}{-20}} + 4 \cdot 10^{\frac{90 - 15 \log(f)}{-20}} \right), 65,0 \text{ max.}$
NOTE ELFEXT values at frequencies that correspond to measured FEXT values of greater than 70,0 dB are for information only.		

1113

1114

Table 13 - ELFEXT limits for a channel at key frequencies

Frequency MHz	Minimum ELFEXT dB		
	Class D	Class E	Class F
0,1	N/A	N/A	N/A
1,0	57,4	63,3	65,0
16,0	33,3	39,2	57,5
100,0	17,4	23,3	44,4
250,0	N/A	15,3	37,8
600,0	N/A	N/A	31,3

1115

1116 **5.4.6.2 Power sum ELFEXT (PSELFEXT)**

1117 The PSELFEXT parameter is applicable to Classes D, E and F only. The PSELFEXT for each pair of a
 1118 channel shall meet the limits computed, to one decimal place, using the formulae of Table 14. The limits
 1119 shown in Table 15 are derived from the formulae at key frequencies only.

1120 PSELFEXT of disturbed pair k , $\alpha_{PSELFEXT}(k)$, is computed from pair-to-pair $\alpha_{ELFEXT}(i,k)$ of the adjacent pairs i ,
 1121 $i = 1 \dots n$ as follows:

1122
$$\alpha_{PSELFEXT}(k) = -10 \log \sum_{i=1, i \neq k}^n 10^{-0,1\alpha_{ELFEXT}(i,k)} \quad (5)$$

1123 where $\alpha_{ELFEXT}(i,k)$ is the pair-to-pair ELFEXT of pair k to adjacent pair i

1124 **Table 14 - Formulae for PSELFEXT limits for a channel**

Class	Frequency MHz	Minimum PSELFEXT dB
D	$1 \leq f \leq 100$	$-20 \log \left(10^{\frac{60,8 - 20 \log(f)}{-20}} + 4 \cdot 10^{\frac{72,1 - 20 \log(f)}{-20}} \right)$
E	$1 \leq f \leq 250$	$-20 \log \left(10^{\frac{64,8 - 20 \log(f)}{-20}} + 4 \cdot 10^{\frac{80,1 - 20 \log(f)}{-20}} \right)$
F	$1 \leq f \leq 600$	$-20 \log \left(10^{\frac{91 - 20 \log(f)}{-20}} + 4 \cdot 10^{\frac{87 - 15 \log(f)}{-20}} \right), 62,0 \text{ max.}$

NOTE PSELFEXT values at frequencies that correspond to measured FEXT values of greater than 70,0 dB are for information only.

1125

1126 **Table 15 - PSELFEXT limits for a channel at key frequencies**

Frequency MHz	Minimum PSELFEXT dB		
	Class D	Class E	Class F
0,1	N/A	N/A	N/A
1,0	54,4	60,3	62,0
16,0	30,3	36,2	54,5
100,0	14,4	20,3	41,4
250,0	N/A	12,3	34,8
600,0	N/A	N/A	28,3

1127 **5.4.7 Direct current (d.c.) loop resistance**

1128 The d.c. loop resistance for each pair of a channel shall be less than the values given in Table 16 for each
 1129 Class of application. When required, the d.c. loop resistance shall be measured according to EN 50346.

1130

Table 16 - Maximum d.c. loop resistance values for a channel

Maximum d.c. loop resistance Ω					
Class A	Class B	Class C	Class D	Class E	Class F
560	170	40	25	25	25

1131 **5.4.8 Direct current (d.c.) resistance unbalance**

1132 The d.c. resistance unbalance between the two conductors within each pair of a channel shall not exceed
1133 3 % for all classes. This shall be achieved by design.

1134 **5.4.9 Direct current (d.c.) power feeding**

1135 Channels of Classes D, E and F shall be designed to support a current of DC 0,175 A per conductor for all
1136 temperatures at which the cabling is intended to be used.

1137 Channels of Classes D, E and F shall be designed to support an operating voltage of DC 72 V between any
1138 conductors for all temperatures at which the cabling is intended to be used.

1139 Relevant application standards and manufacturers' instructions shall be consulted with reference to safety
1140 aspects of power feeding.

1141 Care shall be taken when using multi-unit or bundled cables due to the possible rise of temperature within the
1142 cabling components that may degrade channel performance.

1143 **5.4.10 Operating voltage**

1144 The channels of Classes D, E and F shall support an operating voltage of DC 72 V between any conductors
1145 for all temperatures at which the cabling is intended to be used. This shall be achieved by design.

1146 **5.4.11 Propagation Delay**

1147 The propagation delay for each pair of a channel, measured – when required - according to EN 50346, shall
1148 be less than the limits computed using the formulae, to three decimal places, of Table 17. The limits shown in
1149 Table 18 are derived from the formulae at key frequencies only.

1150

Table 17 - Formulae for propagation delay limits for a channel

Class	Frequency MHz	Maximum propagation delay μs
A	$f = 0,1$	20,000
B	$0,1 \leq f \leq 1$	5,000
C	$1 \leq f \leq 16$	$0,534 + 0,036/\sqrt{f} + 4 \bullet 0,0025$
D	$1 \leq f \leq 100$	$0,534 + 0,036/\sqrt{f} + 4 \bullet 0,0025$
E	$1 \leq f \leq 250$	$0,534 + 0,036/\sqrt{f} + 4 \bullet 0,0025$
F	$1 \leq f \leq 600$	$0,534 + 0,036/\sqrt{f} + 4 \bullet 0,0025$

1151

1152

Table 18 - Propagation delay limits for a channel at key frequencies

Frequency MHz	Maximum propagation delay μs					
	Class A	Class B	Class C	Class D	Class E	Class F
0,1	20,000	5,000	N/A	N/A	N/A	N/A
1,0	N/A	5,000	0,580	0,580	0,580	0,580
16,0	N/A	N/A	0,553	0,553	0,553	0,553
100,0	N/A	N/A	N/A	0,548	0,548	0,548
250,0	N/A	N/A	N/A	N/A	0,546	0,546
600,0	N/A	N/A	N/A	N/A	N/A	0,545

1153 **5.4.12 Delay Skew**

1154 The delay skew parameter is applicable to Classes C, D, E and F only. The delay skew between all pairs of a
 1155 channel, measured – when required - according to EN 50346, shall be less than the limits computed using
 1156 the equations, to three decimal places, of Table 19.

1157

Table 19 - Delay skew limits for a channel

Class	Maximum delay skew μs
C	0,050 ^a
D	0,050 ^a
E	0,050 ^a
F	0,030 ^b

a Calculation is based upon $0,045 + 4 \cdot 0,00125$
 b Calculation is based upon $0,025 + 4 \cdot 0,00125$

1158 **5.4.13 Unbalance attenuation**

1159 Unbalance attenuation, near end, (LCL) shall be achieved by the appropriate choice of cables and
 1160 connections. Unbalance attenuation, near end, (LCL) for the channel shall exceed the values given in
 1161 Table 20.

1162

Table 20 - Maximum unbalance attenuation, near end

Cabling Class	Applicable frequency (range) MHz	Limit dB
A	$f = 0,1$	30
B	0,1 and 1	45 at 0,1 MHz, 20 at 1 MHz
C	$1 \leq f \leq 16$	$30 - 5 \log f$ (ffs)
D	$1 \leq f \leq 100^a$	ffs
E	$1 \leq f \leq 250^a$	ffs
F	$1 \leq f \leq 600^a$	ffs

a Measurement of this parameter above 80 MHz is not well established (i.e. limits are ffs).

1163 5.4.14 Coupling attenuation

1164 The measurement of coupling attenuation for installed cabling is under development. Coupling attenuation of
 1165 a sample installation may be assessed by laboratory measurements of representative samples of channels
 1166 assembled using the components, connector termination practices and installation practices in question. The
 1167 laboratory testing of coupling attenuation is performed using EN 50289-1-6.

1168 5.5 Classification of optical fibre cabling channels

1169 5.5.1 General

1170 This standard specifies the following classes for optical fibre cabling:

- 1171 a) class OF-300 channels support applications listed in Annex E over the optical fibre Categories referenced
 1172 in Clause 7 to a minimum of 300 m;
- 1173 b) class OF-500 channels support applications listed in Annex E over the optical fibre Categories referenced
 1174 in Clause 7 to a minimum of 500 m;
- 1175 c) class OF-2000 channels support applications listed in Annex E over the optical fibre Categories
 1176 referenced in Clause 7 to a minimum of 2 000 m.

1177 The performance requirements for optical fibre channels assume that each optical fibre channel employs a
 1178 single optical wavelength in one transmission window only.

1179 Application standards employing wavelength multiplexing are not yet available for listing in Annex E.

1180 There are no special requirements for generic cabling concerning wavelength multiplexing. The requirements
 1181 for the wavelength multiplexing and de-multiplexing components will be found in the application standards. All
 1182 application-specific hardware for wavelength multiplexing is installed in the equipment area and in the work
 1183 area, both of which are outside the scope of this standard.

1184 5.5.2 Channel Attenuation

1185 The channel attenuation shall not exceed the values shown in Table 21. The values are based on an
 1186 allocation of 1,5 dB for connections.

1187 The attenuation of a channel shall be measured according to

- 1188 a) Annex A.3.2 (Method 1) of EN 50346:2002, for multimode optical fibre,
- 1189 b) method 1.C of EN 61280-4-2:1999, for singlemode optical fibre.

1190 NOTE The test methods have been developed for conventional optical fibre connection systems comprising two plugs and an adaptor.
 1191 In some cases the methods are not appropriate for Small Form Factor connectors that comprise a plug and socket.

1192 **Table 21 - Optical fibre channel attenuation limits**

Class	Maximum channel attenuation dB			
	Multimode		Singlemode	
	850 nm	1300 nm	1310 nm	1550 nm
OF-300	2,55	1,95	1,80	1,80
OF-500	3,25	2,25	2,00	2,00
OF-2000	8,50	4,50	3,50	3,50

1193 **5.5.3 Propagation delay**

1194 For some applications, knowledge of the delay of fibre channels is important to ensure compliance with end-
1195 to-end delay requirements of complex networks consisting of multiple cascaded channels. For this reason, it
1196 is important to know the lengths of the optical fibre channels. It is possible to calculate propagation delay
1197 based on cable performance (see Clause 7).

1198 **6 Reference implementations**

1199 **6.1 General**

1200 This clause describes implementations of generic cabling that utilise components referenced in Clauses 7, 8
1201 and 9. These reference implementations meet the requirements of Clause 4 and, when installed in
1202 accordance with EN 50174, comply with the channel performance requirements of Clause 5.

1203 **6.2 Balanced cabling**

1204 **6.2.1 Assumptions**

1205 Balanced cabling components referenced in Clauses 7, 8 and 9 are defined in terms of impedance and
1206 Category. In the reference implementations of this clause, the components used in each cabling channel shall
1207 meet the following requirements:

- 1208 a) the balanced cables within a Class A, B and C channel shall have a common nominal characteristic
1209 impedance of 100 Ω or 120 Ω ;
- 1210 b) the balanced cables within a Class D, E and F channel shall have a common nominal characteristic
1211 impedance of 100 Ω .

1212 The implementations are based on component performance at 20 °C. The effect of temperature on the
1213 performance of cables shall be taken into account as shown in Table 22 and Table 23.

1214 **6.2.2 Horizontal cabling**

1215 **6.2.2.1 Component choice**

1216 The selection of balanced cabling components will be determined by the class of applications to be supported
1217 by the cabling. Refer to Annex E for guidance.

1218 Using the models of 6.2.2.2:

- 1219 a) Category 5 components provide Class D balanced cabling performance;
- 1220 b) Category 6 components provide Class E balanced cabling performance;
- 1221 c) Category 7 components provide Class F balanced cabling performance.

1222 Cables and connections of different categories may be mixed within a channel however the resultant cabling
1223 performance will be determined by the category of the lowest performing component.

1224 **6.2.2.2 Dimensions**

1225 Figure 11 shows the models used to correlate horizontal cabling dimensions specified in this clause with the
1226 channel specifications in Clause 5.

1227 Figure 11a shows a channel containing only an interconnect and a TO or MUTO.

1228 Figure 11b contains an additional connection as a cross-connect. In both cases the fixed horizontal cable
 1229 connects the FD to the TO. The channel includes cords comprising patch, equipment and work area cords.
 1230 For the purposes of this subclause, jumpers used in place of patch cords are treated as cords.

1231 Figure 11c shows a channel containing an interconnect, a CP and a telecommunications outlet. Figure 11d
 1232 contains an additional connection as a cross-connect. In both cases the fixed horizontal cable connects the
 1233 FD to the CP. The channel includes cords comprising patch, equipment and work area cords. For the
 1234 purposes of this subclause, jumpers used in place of patch cords are treated as cords.

1235 In addition to the cords, the channels shown in Figure 11c and Figure 11d contain a CP cable. The
 1236 attenuation specification for the CP cable may differ from that of both the fixed horizontal cable and the
 1237 flexible cables. The channel of Figure 11d is recognized as the maximum implementation used to define the
 1238 channel performance limits of Clause 5.

1239 In order to accommodate cables used for work area cords, CP cables, patch cords, jumpers and equipment
 1240 cords with different attenuation specifications, the length of the cables used within a channel shall be
 1241 determined by the equations shown in Table 22.

1242 In Table 22 it is assumed that

1243 1) the flexible cable within these cords has a higher attenuation specification than that used in the fixed
 1244 horizontal cable (see Clause 9),

1245 2) the cables within these cords in the channel have a common attenuation specification.

1246

Table 22 - Horizontal channel equations

Model	Figure	Model equations		
		Class D	Class E	Class F
Interconnect – TO	11a	$H = 109 - FX$	$H = 107 - 3^a - FX$	$H = 107 - 2^a - FX$
Cross-connect – TO	11b	$H = 107 - FX$	$H = 106 - 3^a - FX$	$H = 106 - 3^a - FX$
Interconnect - CP –TO	11c	$H = 107 - FX - CY$	$H = 106 - 3^a - FX - CY$	$H = 106 - 3^a - FX - CY$
Cross-connect - CP – TO	11d	$H = 105 - FX - CY$	$H = 105 - 3^a - FX - CY$	$H = 105 - 3^a - FX - CY$
H maximum length of the fixed horizontal cable (m) F combined length of patch cords, jumpers, equipment and work area cords (m) C length of the CP cable (m) X ratio of flexible cable attenuation (dB/m) to fixed horizontal cable attenuation (dB/m) - see Clause 9 Y ratio of CP cable attenuation (dB/m) to fixed horizontal cable attenuation (dB/m) - see Clause 9				
^a This length reduction is to provide an allocated margin to accommodate insertion loss deviation.				
For operating temperatures above 20 °C, H should be reduced by 0,2% per °C for screened cables and 0,4% per °C (20 °C to 40 °C) and 0,6% per °C (>40 °C to 60 °C) for unscreened cables.				

1247 The following general restrictions apply:

1248 – the physical length of the channel shall not exceed 100 m;

1249 – the physical length of the fixed horizontal cable shall not exceed 90 m and may be less depending on the
 1250 length of CP cables and cords used and the number of connections;

1251 – where a multi-user TO assembly is used, the length of the work area cord should not exceed 20 m;

- 1252 – when used, a CP should be located at least 15 m from the floor distributor in order to reduce the effect of
- 1253 multiple connections in close proximity on NEXT and return loss;

- 1254 – the length of patch cords or jumpers should not exceed 5 m.

- 1255 The maximum length of the fixed horizontal cable will depend on the total length of CP cables and cords to be
- 1256 supported within a channel. During the operation of the installed cabling, a management system should be
- 1257 implemented to ensure that the cords and, where appropriate, the CP cables used to create the channel
- 1258 conform with the design rules for the floor, building or installation.

Draft for Vote

1259

a) Interconnect - TO Model

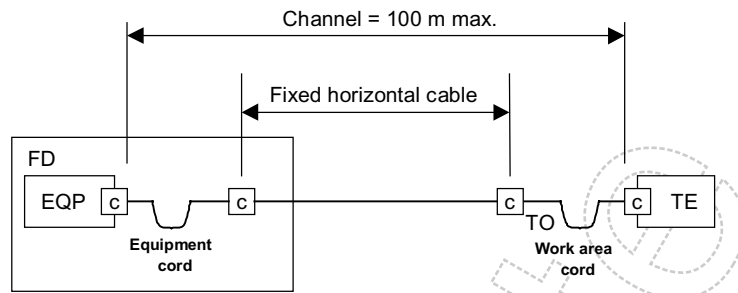

b) Crossconnect - TO Model

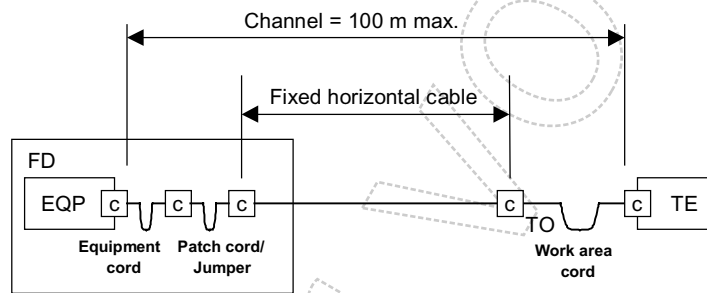

c) Interconnect - CP - TO Model

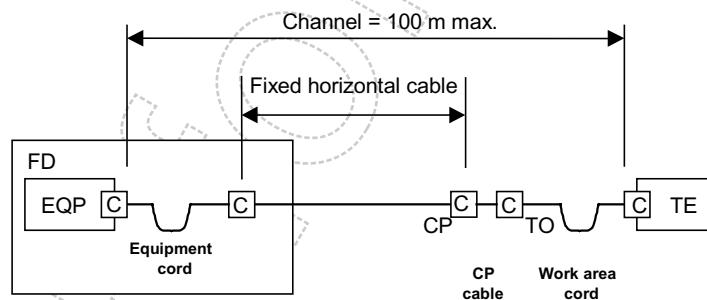

d) Crossconnect - CP - TO Model

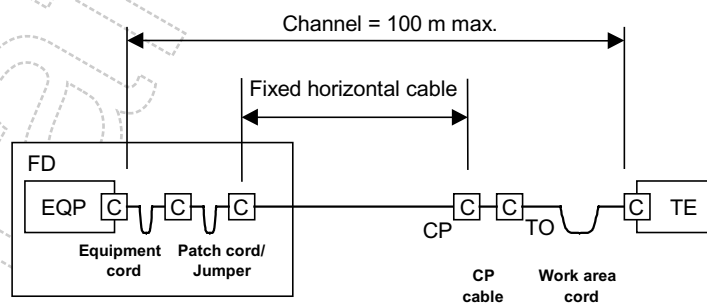

Figure 11 - Horizontal cabling models

1260

1261

1262 **6.2.3 Backbone cabling**

1263 **6.2.3.1 Component choice**

1264 The selection of balanced cabling components will be determined by the channel lengths required and the
1265 class of applications to be supported. Refer to Annex E for guidance.

1266 **6.2.3.2 Dimensions**

1267 Figure 12 shows the model used to correlate cabling dimensions specified in this clause with the channel
1268 specifications in Clause 5. The backbone channel shown (either building or campus) contains a cross-
1269 connect at both ends. This represents the worst-case configuration for a backbone channel.

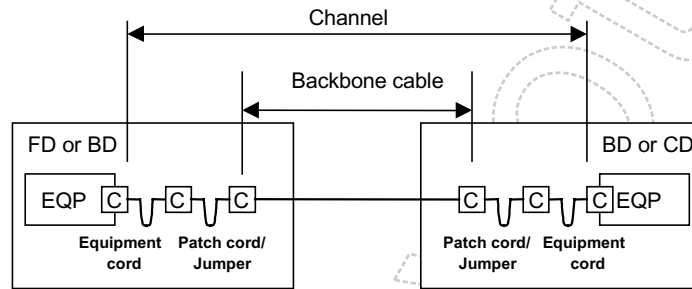

1270 **Figure 12 - Backbone cabling model**

1271 The channel includes cords comprising patch and equipment cords. For the purposes of this clause, jumpers
1272 used in place of patch cords are treated as cords.

1273 In Table 23 it is assumed that

1274 a) the flexible cable within these cords has a higher attenuation specification than that used in the fixed
1275 backbone cable,

1276 b) the cables within all these cords in the channel have a common attenuation specification.

1277 In order to accommodate the higher attenuation of stranded cables used for cords, the length of the cables
1278 used within a channel of a given class (see Clause 5) shall be determined by the equations shown in
1279 Table 23.

1280 When four connections are used in a channel, the physical length of the backbone cable should be at least
1281 15 m.

1282 The maximum length of the fixed backbone cable will depend on the total length of cords to be supported
1283 within a channel. The maximum lengths of cords shall be fixed for distributors and during the operation of the
1284 installed cabling, a management system should be implemented to ensure that the cords used to create the
1285 channel conform with these design limits.

1286

Table 23 - Backbone channel equations

Component Category	Class ^a					
	A	B	C	D	E	F
5	2000	B = 250 - FX	B = 170 - FX	B = 105 - FX	-	-
6	2000	B = 260 - FX	B = 185 - FX	B = 111 - FX	B = 105 - 3 ^b - FX	
7	2000	B = 260 - FX	B = 190 - FX	B = 115 - FX	B = 107 - 3 ^b - FX	B = 105 - 3 ^b - FX

B length of the fixed backbone cable (m)
F combined length of patch cords, jumpers and equipment cords (m)
X ratio of flexible cable attenuation (dB/m) to fixed backbone cable attenuation (dB/m) – see Clause 9

^a Applications limited by propagation delay or skew may not be supported if channel lengths exceed 100 m.
^b This length reduction is to provide an allocated margin to accommodate insertion loss deviation.

Where channels contain a different number of connections than in the model shown in Figure 8, the fixed cable length shall be reduced (where more connections exist) or may be increased (where fewer connections exist) by 2 m per connection for Category 5 cabling and 1 m per connection for Category 6 and 7 components. Additionally, the NEXT, Return Loss and ELFEXT performance should be verified.

For operating temperatures above 20 °C, B should be reduced by 0,2 % per °C for screened cables and 0,4 % per °C (20 °C to 40 °C) and 0,6 % per °C (>40 °C to 60 °C) for unscreened cables.

1287

1288 **6.3 Optical fibre cabling**1289 **6.3.1 Assumptions**

1290 Optical fibre components are referenced in Clauses 7, 8 and 9. The optical fibres are defined in terms of
1291 physical construction (core/cladding diameter) and Category. Within the reference implementations of this
1292 clause, the optical fibres used in each cabling channel shall have the same physical construction specification
1293 and be of the same Category.

1294 When more than one physical construction or cable Category is used in a cabling subsystem the cabling shall
1295 be marked to allow each cabling type to be clearly identified.

1296 **6.3.2 Component choice**

1297 The selection of optical fibre components will be determined by the channel lengths required and the
1298 applications to be supported. Refer to Annex E for guidance.

1299 **6.3.3 Optical fibre channel lengths**

1300 The models of Figure 11 and Figure 12 are applicable to horizontal and backbone optical fibre cabling
1301 respectively. It should be noted that the connection systems used to terminate fixed optical cabling may
1302 contain mated connections and splices (permanent or re-useable) and that cross-connects may comprise re-
1303 useable splices.

1304 The delivery of optical fibre to the TO would not generally require transmission equipment at the FD (unless
1305 the design of optical fibre in the backbone cabling subsystem differed from that in the horizontal cabling
1306 subsystem). This allows the creation of a combined backbone/horizontal channel as shown in Figure 13. The
1307 three diagrams show a patched channel, a spliced channel and a direct channel (which does not require the
1308 use of a FD). Patched and spliced channel designs are also applicable to combined campus/building
1309 backbone channels and it is possible to consider a combined campus/building/horizontal channel.

1310 The use of permanently spliced and direct channels as a means of reducing channel attenuation and/or
1311 centralizing the distribution of applications is also a reduction in the overall flexibility of generic cabling.

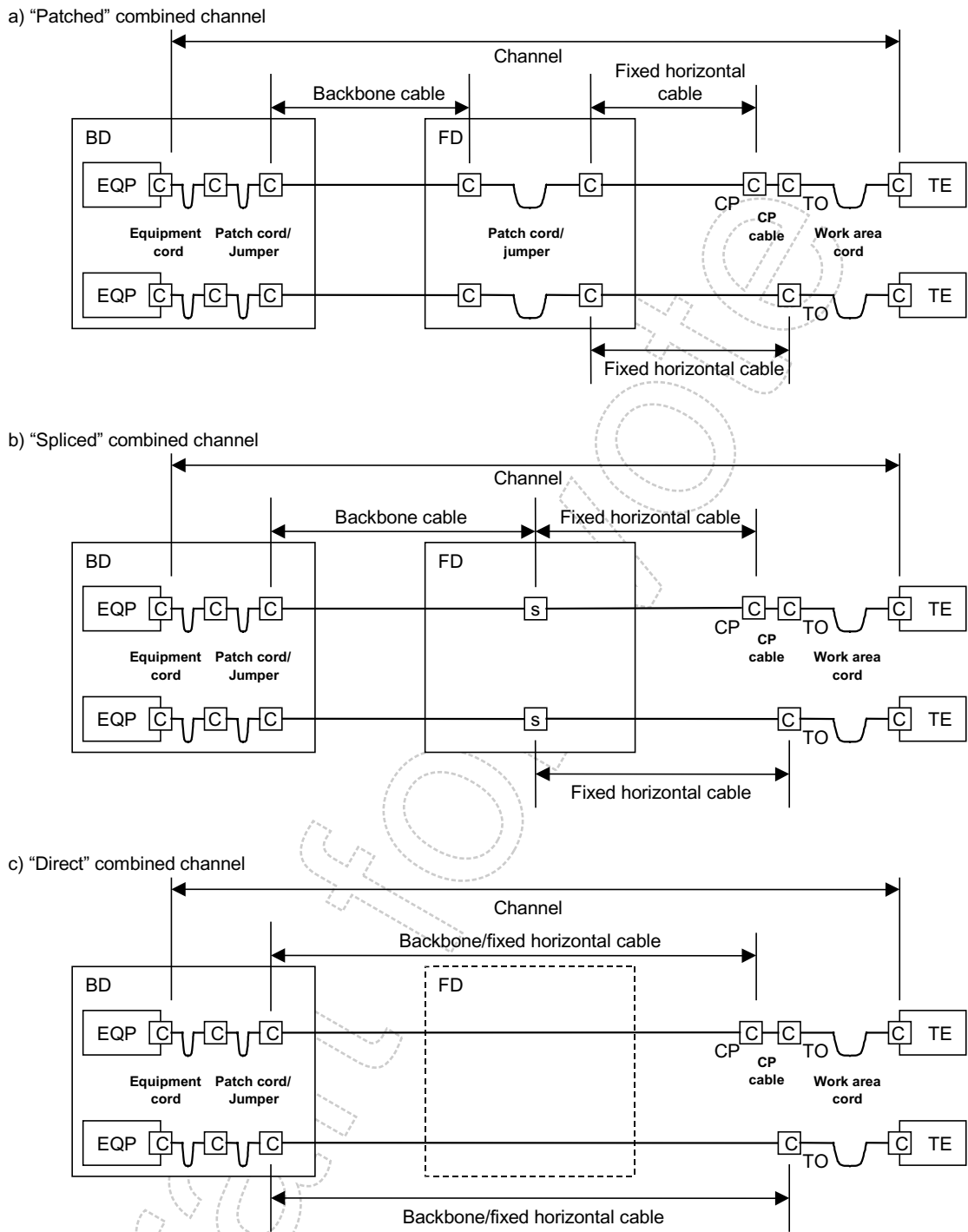

1312 **Figure 13 - Combined optical fibre backbone/horizontal channels**

1313 In order to accommodate differing quantities of mated connections and splices of the cables used within a
 1314 channel of a given class (see Clause 5), the total length of the channel length shall be determined by the
 1315 equations shown in Table 24.

1316 NOTE The equations of Table 24 may not support the implementation of all the channel configurations shown in Figure 13.

1317

Table 24 - Optical fibre channel parameters

Optical fibre type	Class	Implementation equations ^a		Maximum length m
Multimode		850 nm	1300 nm	
Cable Category	OF-300	$L = 735-145x-90y$	$L = 1300-330x-200y$	300
OM1/OM2/OM3	OF-500	$L = 935-145x-90y$	$L = 1500-330x-200y$	500
	OF-2000	$L = 2435-145x-90y$	$L = 3000-330x-200y$	2 000
Singlemode		1310 nm	1550 nm	
OS1	OF-300	$L = 1800-500x-300y$	$L = 1800-500x-300y$	300
	OF-500	$L = 2000-500x-300y$	$L = 2000-500x-300y$	500
	OF-2000	$L = 3500-500x-300y$	$L = 3500-500x-300y$	2 000
L length of the channel (m)				
x total number of mated connections in the channel				
y total number of splices in the channel				
^a These equations assume 0,5 dB attenuation per mated connection (as for a two connection system only 0,25 % would exceed that value)				

1318 Additional connections/splices may be used if the optical power budget of the application allows (see
1319 Annex E).

1320 7 Cable requirements

1321 7.1 General

1322 This clause defines the minimum requirements for

1323 a) cables installed in the horizontal and backbone cabling subsystems specified in Clause 4 and used in the
1324 reference implementations of Clause 6,

1325 b) balanced cables or cable elements to be used as jumpers,

1326 c) flexible balanced cables to be assembled as cords as specified in Clause 9 and used in the reference
1327 implementations of Clause 6.

1328 Balanced cables shall meet the generic specification EN 50288-1 and the sectional specifications as defined
1329 in 7.2.

1330 Optical fibre cables shall meet the generic specification EN 60794-1-1 and the sectional specifications as
1331 defined in 7.4.

1332 7.2 Balanced cables

1333 7.2.1 Basic performance requirements

1334 Both mechanical and electrical requirements are given in the generic specification EN 50288-1 and the rele-
1335 vant sectional specifications (see Table 25) and cover the minimum requirements to meet the performance
1336 classes specified in Clause 5.

1337 Table 25 indicates the applicable standards for balanced cables.

1338

Table 25 - Balanced cable standards

Cable category	Applicable standard for solid cables	Applicable standard for flexible cables
5	prEN 50288-2-1:200X prEN 50288-3-1:200X	prEN 50288-2-2:200X prEN 50288-3-2:200X
6	prEN 50288-5-1:200X prEN 50288-6-1:200X	prEN 50288-5-2:200X prEN 50288-6-2:200X
7	prEN 50288-4-1:200X	prEN 50288-4-2:200X

1339

1340 **7.2.2 Additional performance requirements**

1341 The equations contained within the specifications listed in Table 25 that define the requirements for return
1342 loss are normative requirements of this European standard.

1343 **7.3 Hybrid and multi-unit cables, and cables connected to more than one telecommunications**
1344 **outlet**

1345 Examples of the types of cables that are covered by this subclause include hybrid cables, multi-unit cables
1346 and any cable connected to more than one telecommunications outlet (either directly or through a
1347 consolidation point).

1348 Cables required to meet this subclause shall also meet the transmission requirements for the corresponding
1349 cable category and type given in 7.2. Additionally, the PSNEXT between all non-fibre recognised cable units
1350 or elements shall be 3 dB better than the specified pair-to-pair NEXT required at all specified frequencies
1351 according to 7.2 for the same category.

1352 **7.4 Optical fibre cables**

1353 **7.4.1 Multimode optical fibre cables**

1354 The optical fibre shall be multimode, graded-index optical fibre waveguide with nominal 50/125 µm or
1355 62,5/125 µm core/cladding diameter complying with A1a or A1b optical fibre, respectively, of
1356 EN 60793-2-10:2002.

1357 Each optical fibre in the cable shall meet the performance requirements of Table 26. Both attenuation and
1358 modal bandwidth-distance product shall be measured in accordance with EN 60793-1-40 and EN 60793-1-41
1359 respectively.

1360

Table 26 - Multimode optical fibre cable performance requirements

Category	Maximum attenuation (dB/km)		Minimum modal bandwidth MHz.km		
			Overfilled launch		Effective laser launch ^a
	850 nm	1 300 nm	850 nm	1 300 nm	850 nm
OM1	3,5	1,5	200	500	not specified
OM2	3,5	1,5	500	500	not specified
OM3 ^b	3,5	1,5	1 500	500	2 000

^a Effective laser launch bandwidth is assured using differential mode delay (DMD) as specified in draft EN 60793-1-49. Optical fibres that meet only the overfilled launch modal bandwidth may not support some applications listed in Annex E.

^b OM3 can only be realized with 50/125 µm fibres.

1361

1362 The mechanical and environmental requirements for indoor and outdoor optical fibre cables are defined in
1363 accordance with EN 60794-1-1, EN 60794-1-2, IEC 60794-2 and EN 60794-3.

1364 **7.4.2 Singlemode optical fibre cables**

1365 The optical fibre shall comply with B1 fibre of EN 60793-2-50:2002.

1366 Each optical fibre in the cable shall have an attenuation as defined in Table 27. The attenuation shall be
1367 measured in accordance with EN 60793-1-40.

1368 **Table 27 - Singlemode optical fibre cable (Category OS1) performance requirements**

Wavelength nm	Maximum attenuation dB/km
1 310	1,0
1 550	1,0

1369 The cut-off wavelength of singlemode optical fibre cables shall be less than 1 260 nm when measured in
1370 accordance with EN 60793-1-44.

1371 The mechanical and environmental requirements for indoor and outdoor optical fibre cables are defined in
1372 accordance with EN 60794-1-1, EN 60794-1-2, IEC 60794-2 and EN 60794-3.

1373 **7.4.3 Propagation delay**

1374 For all fibre categories defined in Tables 26 and 27 a conservative conversion value for unit propagation
1375 delay of 5,00 ns/m (0,667 c) may be used. This value can be used to calculate channel delay without
1376 verification.

1377 **7.4.4 Marking**

1378 The category of the optical fibre(s) within the cable shall be marked upon the cable sheath.

1379 **8 Connecting hardware requirements**

1380 **8.1 General requirements**

1381 **8.1.1 Overview**

1382 This clause provides guidelines and requirements for connecting hardware used with generic cabling. For the
1383 purposes of this clause, connecting hardware (sometimes referred to as a connection) is considered to
1384 consist of a device or a combination of devices used to connect cables or cable elements. Unless otherwise
1385 specified, this standard specifies the minimum performance of mated connectors as part of a permanent link
1386 or channel. These requirements apply to individual connectors which include telecommunications outlets,
1387 patch panels, consolidation point connectors, splices and cross-connects. Performance requirements do not
1388 include the effects of cross-connect jumpers or patch cords. Requirements for balanced cords are provided in
1389 Clause 9.

1390 **NOTE** This clause does not address requirements for media adapters or other devices with passive or active electronic circuitry (for
1391 example, impedance matching transformers, terminating resistors, LAN equipment, filters and protection devices) whose main purpose is
1392 to serve a specific application or to provide compliance with other rules and regulations. When required, such devices are not considered
1393 to be part of the cabling and may have significant detrimental effects on network performance. Therefore, it is important that their
1394 compatibility with the cabling system and active equipment be considered before use.

1395 **8.1.2 Location**

1396 Connecting hardware is installed:

- 1397 a) in a campus distributor permitting connections to building backbone and campus backbone cabling and
1398 equipment (if provided);
- 1399 b) in a building distributor permitting connections to the backbone cabling and equipment (if provided);
- 1400 c) in a floor distributor providing the cross-connections between backbone and horizontal cabling and
1401 permitting connections to equipment (if provided);
- 1402 d) at the horizontal cabling consolidation point (if provided);
- 1403 e) at the telecommunications outlet;
- 1404 f) in the building entrance facility (BEF).

1405 **8.1.3 Design**

1406 In addition to its primary purpose, the connecting hardware should be designed to provide:

- 1407 a) a means to identify cabling for installation and administration as described in EN 50174-1;
- 1408 b) a means to permit orderly cable management;
- 1409 c) a means of access to monitor or test cabling and active equipment;
- 1410 d) protection against physical damage and ingress of contaminants that may affect performance;
- 1411 e) a termination density that is space efficient, but that also provides ease of cable management and
1412 ongoing administration of the cabling system;
- 1413 f) a means to accommodate screening and grounding requirements, when applicable.

1414 This European standard specifies the types of connecting hardware to be used at the Telecommunications
1415 Outlet. It is possible to use alternative connecting hardware at other locations provided that it meets the
1416 relevant requirements of this clause.

1417 **8.1.4 Operating environment**

1418 The performance of the connecting hardware shall be maintained over the temperature range -10 °C to
1419 60 °C.

1420 **8.1.5 Mounting**

1421 Connecting hardware shall be designed to provide flexibility for mounting in closures as described in
1422 EN 50174-1.

1423 **8.1.6 Installation practices**

1424 Installation practices should be in accordance with EN 50174-1, EN 50174-2 and EN 50174-3.

1425 **8.1.7 Marking and colour coding**

1426 In order to maintain consistent and correct point-to-point connections, provision shall be made to ensure that
1427 terminations are properly located with respect to connector positions and their corresponding cable elements.
1428 Such provision may include the use of colours, alphanumeric identifiers or other means designed to ensure
1429 that cables are connected in a consistent manner throughout the system. See EN 50174-1 for further
1430 information.

1431 **8.2 Connecting hardware for balanced cabling**

1432 **8.2.1 General requirements**

1433 The following requirements apply to all connecting hardware used to provide electrical connections with
1434 balanced cables described in Clause 7. When connecting hardware used to directly terminate cable elements
1435 is of the solderless connection type, e.g. insulation displacement connection (IDC) it shall meet the require-
1436 ments of series EN 60352. In addition to the requirements of this subclause, connecting hardware used with
1437 screened cabling shall be in full compliance with the applicable requirements of series EN 50174.

1438 Assurance should be sought from suppliers that the combinations of components within connecting hardware
1439 are able to meet the electrical and mechanical requirements of this clause.

1440 **8.2.2 Performance marking**

1441 Connecting hardware intended for use with balanced cabling should be marked to designate transmission
1442 performance at the discretion of the manufacturer. The markings, if any, shall be visible during installation.

1443 NOTE Performance markings are in addition to, and do not replace, other markings specified in 8.1.6, EN 50174-1 or those required by
1444 local codes or regulations.

1445 **8.2.3 Mechanical characteristics**

1446 Connecting hardware intended for use with balanced cabling shall meet the requirements of Table 28.

1447

1448 **Table 28 - Mechanical characteristics of connecting hardware intended for use with balanced cabling**

	Characteristic	Requirement	Reference
a)	Cable termination compatibility		
	Nominal conductor diameter	0,5 mm to 0,65 mm ¹⁾	--
	Conductor type	solid	EN 50288-X-2 or EN 50288-X-1
	Conductor type	stranded	EN 50288-X-2
	Nominal diameter of insulated conductor Category 5 and Category 6 Category 7	0,7 mm to 1,4 mm ^{2),3)} 0,7 mm to 1,6 mm	8.1 of EN 60811-1-1:1995
	Number of conductors (TO)	8	visual inspection
	Number of conductors (other)	≥ 2*n (n = 1,2,3, ...)	
	Cable outer diameter outlet plug	≤ 20 mm ≤ 9 mm ⁴⁾	8.2 of EN 60811-1-1:1995
	Means to connect screen	EN 50174-2 ⁵⁾	
b)	Mechanical operation (durability) --		
	Cable termination		
	Non-reusable IDC	1	EN 60352-3 and EN 60352-4
	Reusable IDC	≥ 20	EN 60352-3 and EN 60352-4
	Non-reusable IPC	1	EN 60352-6
	Jumper termination (cycles)	≥ 200 ⁶⁾	EN 60352-3 and EN 60352-4
	TO type interface (cycle)	≥ 750 (level PL1 of EN 60603-7) ⁷⁾	Clauses 6 and 7 of EN 60603-7:1996
	other interface (cycles)	≥ 200 (see Annex D)	EN 60352-6
<p>1) Nominal conductor diameters described in EN 50288-X-Y allow conductor diameters ranging from 0,4 mm to 0,8 mm, connecting hardware described in this clause is limited to 0,4 mm to 0,55 mm for plugs and 0,5 mm to 0,65 mm for jacks or punch down blocks.</p> <p>2) Use of the modular plug connector specified in EN 60603-7-X is typically limited to cables having insulated conductor diameters in the range of 0,8 mm to 1,0 mm.</p> <p>3) Because it is not required for connecting hardware to be compatible with cables outside of this range, special care shall be taken to ensure compatibility between cables with insulated conductor diameters as high as 1,6 mm (when used) and the connecting hardware they are used with.</p> <p>4) Use of the modular plug connector specified in EN 60603-7-X is typically limited to cables having outside diameters in the range of 5 mm to 8 mm. Flat/oval cables with equivalent cross-sectional area are acceptable.</p> <p>5) If it is intended to use screened cabling, care should be taken that the cross-connect is designed to terminate the screening. Note that there may be a difference between cross-connects designed to terminate balanced cables with overall screens only, as opposed to cables having both individually screened elements and an overall screen.</p> <p>6) This durability requirement is only applicable to connections designed for more than a single termination operation (for example, those that are used to administer cabling system changes).</p> <p>7) Mating and unmating under load is ffs.</p>			

1450 **8.2.4 Electrical characteristics**1451 **8.2.4.1 General**

1452 Connecting hardware intended for use with balanced cabling shall meet the corresponding performance
 1453 requirements of 8.2.4.2 to 8.2.4.16. Connecting hardware shall be tested with each cable impedance that it is
 1454 intended to support. When connectors complying with the mechanical requirements of EN 60603-7 are used,
 1455 the connectors shall comply with all requirements of the relevant parts of EN 60603-7 for the relevant
 1456 category.

1457 Plugs and sockets that are intermateable shall be backward compatible with those of different performance
 1458 categories. Backward compatibility means that mated connections with plugs and sockets from different
 1459 categories shall meet all requirements for the lower category component. See Table 29 for a matrix of mated
 1460 modular connector performance that is representative of backward compatible connectivity.

1461 **Table 29 - Backwards compatibility matrix**

Modular plug/cord	Modular connector (TO) Category		
	Category 5	Category 6	Category 7
Category 5	Category 5	Category 5	Category 5
Category 6	Category 5	Category 6	Category 6
Category 7	Category 5	Category 6	Category 7

1462

1463 **8.2.4.2 Return loss**

1464 The return loss of connecting hardware shall meet the limits computed, to one decimal place, using the
 1465 formulae of Table 30. The limits shown in Table 31 are derived from the formulae at key frequencies only.

1466 **Table 30 - Formulae for return loss limits for connecting hardware**

Category	Frequency MHz	Minimum return loss dB
5	$1 \leq f \leq 100$	$60 - 20 \cdot \log(f)$, 30,0 max.
6	$1 \leq f \leq 250$	$64 - 20 \cdot \log(f)$, 30,0 max.
7	$1 \leq f \leq 600$	$68 - 20 \cdot \log(f)$, 30,0 max.

1467

1468 **Table 31 - Minimum return loss**

Frequency MHz	Minimum return loss dB			Component or test standard
	Category 5	Category 6	Category 7	
1,0	30,0	30,0	30,0	EN 60512-25-5
16,0	30,0	30,0	30,0	
100,0	20,0	24,0	24,0	
250,0	N/A	16,0	16,0	
600,0	N/A	N/A	12,4	

1469

1470 **8.2.4.3 Attenuation / insertion loss**

1471 The attenuation of connecting hardware measured as insertion loss shall not exceed the limits computed, to
 1472 two decimal places, using the formulae of Table 32. The limits shown in Table 33 are derived from the
 1473 formulae at key frequencies only.

1474 **Table 32 - Formulae for attenuation limits for connecting hardware**

Category	Frequency MHz	Maximum attenuation/insertion loss dB
5	$1 \leq f \leq 100$	$0,04\sqrt{f}$, 0,10 min.
6	$1 \leq f \leq 250$	$0,02\sqrt{f}$, 0,10 min.
7	$1 \leq f \leq 600$	$0,02\sqrt{f}$, 0,10 min.

1475

1476 **Table 33 - Maximum attenuation (insertion loss)**

Frequency MHz	Maximum attenuation (insertion loss) dB			Component or test standard
	Category 5	Category 6	Category 7	
1,0	0,10	0,10	0,10	EN 60512-25-2
16,0	0,16	0,10	0,10	
100,0	0,40	0,20	0,20	
250,0	N/A	0,32	0,32	
600,0	N/A	N/A	0,49	

1477

1478 **8.2.4.4 NEXT**

1479 The NEXT of connecting hardware shall meet the limits computed, to one decimal place, using the formulae
 1480 of Table 34. The limits shown in Table 35 are derived from the formulae at key frequencies only.

1481 **Table 34 – Formulae for NEXT limits for connecting hardware**

Category	Frequency MHz	Minimum NEXT dB
5	$1 \leq f \leq 100$	$83 - 20 \cdot \log(f)$, 80,0 max.
6	$1 \leq f \leq 250$	$94 - 20 \cdot \log(f)$, 80,0 max.
7	$1 \leq f \leq 600$	$102,4 - 15 \cdot \log(f)$, 80,0 max.

1482

1483 **Table 35 - Minimum NEXT**

Frequency MHz	Minimum NEXT dB			Component or test standard
	Category 5	Category 6	Category 7	
1,0	80,0	80,0	80,0	EN 60512-25-1
16,0	58,9	69,9	80,0	
100,0	43,0	54,0	72,4	
250,0	N/A	46,0	66,4	
600,0	N/A	N/A	60,8	

1484 **8.2.4.5 PSNEXT**

1485 The PSNEXT of connecting hardware shall meet the limits computed, to one decimal place, using the
 1486 formulae of Table 36. The limits shown in Table 37 are derived from the formulae at key frequencies only.

1487 **Table 36 - Formulae for PS NEXT limits for connecting hardware**

Category	Frequency MHz	Minimum PSNEXT dB
5	$1 \leq f \leq 100$	$80 - 20 \cdot \log(f)$, 77,0 max.
6	$1 \leq f \leq 250$	$90 - 20 \cdot \log(f)$, 77,0 max.
7	$1 \leq f \leq 600$	$99,4 - 15 \cdot \log(f)$, 77,0 max.

1488

1489

Table 37 - Minimum PSNEXT

Frequency MHz	Minimum PSNEXT dB			Component or test standard
	Category 5	Category 6	Category 7	
1,0	75,9	77,0	77,0	EN 60512-25-1
16,0	55,9	65,9	77,0	
100,0	40,0	50,0	69,4	
250,0	N/A	42,0	63,4	
600,0	N/A	N/A	57,8	

1490

1491 **8.2.4.6 FEXT**

1492 The FEXT of connecting hardware shall meet the limits computed, to one decimal place, using the formulae
 1493 of Table 38. The limits shown in Table 39 are derived from the formulae at key frequencies only.

1494 NOTE For connectors, the difference between FEXT and ELFEXT is minimal. Therefore, connector FEXT requirements are used to
 1495 model ELFEXT performance for channels.

1496 **Table 38- Formulae for FEXT limits for connecting hardware**

Category	Frequency MHz	Minimum FEXT dB
5	$1 \leq f \leq 100$	$75,1 - 20 \cdot \log(f)$, 65,0 max.
6	$1 \leq f \leq 250$	$83,1 - 20 \cdot \log(f)$, 65,0 max.
7	$1 \leq f \leq 600$	$90 - 15 \cdot \log(f)$, 65,0 max.

1497

1498

Table 39 - Minimum FEXT

Frequency MHz	Minimum FEXT dB			Component or test standard
	Category 5	Category 6	Category 7	
1,0	65,0	65,0	65,0	EN 60512-25-1
16,0	51,0	59,0	65,0	
100,0	35,1	43,1	60,0	
250,0	N/A	35,1	54,0	
600,0	N/A	N/A	48,3	

1499 **8.2.4.7 PSFEXT**

1500 The PSFEXT of connecting hardware shall meet the limits computed, to one decimal place, using the
1501 formulae of Table 40. The limits shown in Table 41 are derived from the formulae at key frequencies only.

1502 NOTE For connectors, the difference between PSFEXT and PSELFEXT is minimal. Therefore, connector PSFEXT requirements are
1503 used to model PSELFEXT performance for channels.

1504 **Table 40 - Formulae for PSFEXT limits for connecting hardware**

Category	Frequency MHz	Minimum PSFEXT dB
5	$1 \leq f \leq 100$	$72,1 - 20 \cdot \log(f)$, 62,0 max.
6	$1 \leq f \leq 250$	$80,1 - 20 \cdot \log(f)$, 62,0 max.
7	$1 \leq f \leq 600$	$87 - 15 \cdot \log(f)$, 62,0 max.

1505

1506

Table 41 - Minimum PSFEXT

Frequency MHz	Minimum PSFEXT dB			Component or test standard
	Category 5	Category 6	Category 7	
1,0	62,0	62,0	62,0	EN 60512-25-1
16,0	48,0	56,0	62,0	
100,0	32,1	40,1	57,0	
250,0	N/A	32,1	51,0	
600,0	N/A	N/A	45,3	

1507

1508 **8.2.4.8 Propagation delay**

1509 The propagation delay of connecting hardware shall not exceed the limits of Table 42.

1510 **Table 42 - Formulae for propagation delay for connecting hardware**

Category	Frequency MHz	Maximum propagation delay μ s	Component or test standard
5	$1 \leq f \leq 100$	0,002 5	EN 60512-25-4
6	$1 \leq f \leq 250$	0,002 5	
7	$1 \leq f \leq 600$	0,002 5	

1511

1512 **8.2.4.9 Delay skew**

1513 The delay skew of connecting hardware shall not exceed the limits of Table 43.

1514 **Table 43 - Formulae for delay skew for connecting hardware**

Category	Frequency MHz	Maximum delay skew μs	Component or test standard
5	$1 \leq f \leq 100$	0,001 25	EN 60512-25-4
6	$1 \leq f \leq 250$	0,001 25	
7	$1 \leq f \leq 600$	0,001 25	

1515

1516 **8.2.4.10 Input to output resistance**

1517 Input to output resistance is a separate measurement from the contact resistance measurements required in
 1518 EN 60603-7. Input to output resistance is measured from cable termination to cable termination to determine
 1519 the connector's ability to transmit direct current and low frequency signals. Contact resistance measurements
 1520 are used to determine the reliability and stability of individual electrical connections. These requirements are
 1521 applicable to each conductor and to the screen, when present.

1522 The input/output resistance of connecting hardware shall not exceed the limits of Table 44.

1523 **Table 44 – Maximum input to output resistance**

Frequency MHz	Maximum input to output resistance $\text{m}\Omega$			Component or test standard
	Category 5	Category 6	Category 7	
d.c.	200	200	200	Test 2a of EN 60512-2:1985

1524

1525 **8.2.4.11 Input to output resistance unbalance**

1526 The input/output resistance unbalance of connecting hardware shall not exceed the limits of Table 45.

1527 **Table 45 – Maximum input to output resistance unbalance**

Frequency MHz	Maximum input to output resistance unbalance $\text{m}\Omega$			Component or test standard
	Category 5	Category 6	Category 7	
d.c.	50	50	50	Test 2a of EN 60512-2:1985

1528

1529 **8.2.4.12 Current carrying capacity**

1530 The current carrying capacity of connecting hardware shall meet the limits of Table 46. The requirements are
 1531 applicable to each conductor including the screen, if present, and for an ambient temperature of 60 °C. The
 1532 sample preparation shall be as specified in EN 60603-7.

1533

Table 46 - Minimum current carrying capacity

Frequency MHz	Minimum current capacity per conductor A			Component or test standard
	Category 5	Category 6	Category 7	
d.c.	0,75	0,75	0,75	Test 5b of IEC 60512-3:1976

1534

1535 **8.2.4.13 Transfer impedance**

1536 The transfer impedance of connecting hardware shall meet the limits computed, to two decimal places, using
1537 the formulae of Table 47. The limits shown in Table 48 are derived from the formulae at key frequencies only.

1538

Table 47 - Formulae for transfer impedance for connecting hardware

Category	Frequency MHz	Maximum transfer impedance Ω
5	$1 \leq f \leq 10$	$0,1 \cdot f^{0,3}$
	$10 < f \leq 30$	$0,02 \cdot f$
6	$1 \leq f \leq 10$	$0,1 \cdot f^{0,3}$
	$10 < f \leq 30$	$0,02 \cdot f$
7	$1 \leq f \leq 10$	$0,05 \cdot f^{0,3}$
	$10 < f \leq 30$	$0,01 \cdot f$

1539

1540

Table 48 - Maximum transfer impedance

Frequency MHz	Maximum transfer impedance Ω			Component or test standard
	Category 5	Category 6	Category 7	
1,0	0,10	0,10	0,05	EN 60512-25-5
16,0	0,32	0,32	0,16	
30,0	0,60	0,60	0,30	
100,0	N/A	N/A	N/A	
250,0	N/A	N/A	N/A	
600,0	N/A	N/A	N/A	

1541

1542 **8.2.4.14 Unbalance attenuation**

1543 Unbalance attenuation, near end, (LCL) shall meet the limits computed, to two decimal places, using the
1544 formulae of Table 49. The limits shown in Table 50 are derived from the formulae at key frequencies only.

1545 **Table 49 - Formulae for Transverse Conversion Loss (TCL) limits for connecting hardware**

Category	Frequency MHz	Minimum TCL dB
5	$1 \leq f \leq 100$	$66 - 20 \cdot \log(f)$, 60,00 max.
6	$1 \leq f \leq 250$	$66 - 20 \cdot \log(f)$, 60,00 max.
7	$1 \leq f \leq 600$	$66 - 20 \cdot \log(f)$, 60,00 max.

1546

1547

Table 50 - Minimum TCL

Frequency MHz	Minimum balance dB			Component or test standard
	Category 5	Category 6	Category 7	
1,0	60,0	60,0	60,0	Annex K of EN 60603-7-7 :2002
16,0	41,9	41,9	41,9	
100,0	26,0	26,0	26,0	
250,0	N/A	18,0	18,0	
600,0	N/A	N/A	10,4	

NOTE This test method is applicable to all connecting hardware.

1548

1549 **8.2.4.15 Insulation resistance**

1550 The insulation resistance of connecting hardware shall exceed the limits of Table 51.

1551

Table 51 – Minimum insulation resistance

Frequency MHz	Minimum insulation resistance M Ω			Component or test standard
	Category 5	Category 6	Category 7	
d.c.	100	100	100	Test 3a, Method C of EN 60512-2:1985 at DC 500 V

1552

1553 **8.2.4.16 Voltage proof**

1554 The voltage proof of connecting hardware shall exceed the limits of Table 52.

1555

Table 52 – Minimum d.c. voltage proof

Characteristic	Minimum d.c. voltage proof V			Component or test standard
	Category 5	Category 6	Category 7	
Conductor to conductor	1 000	1 000	1 000	Test 4a of EN 60512-2:1985
Conductor to test panel	1 500	1 500	1 500	

1556

1557 **8.2.5 Environmental characteristics**

1558 **8.2.5.1 Connecting hardware of the type used at the telecommunications outlet**

1559 See the EN 60603-7 series of standards.

1560 **8.2.5.2 Other types of connecting hardware**

1561 See Annex D.

1562 **8.2.6 Telecommunications outlet requirements**

1563 Pin and pair grouping assignments shall be as shown in Figure 14

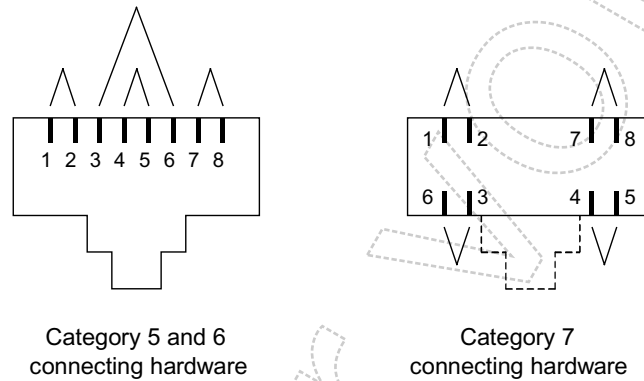

1564

Figure 14 - Eight position jack pin and pair grouping assignments (front view of connector)

1565
1566

1567 Pair rearrangement at the telecommunications outlet should not involve modification of the horizontal cable
1568 terminations. If pair rearrangement is used at the telecommunications outlet, the configuration of the outlet
1569 terminations shall be clearly identified.

1570 NOTE When two physically similar cabling links are used in the same installation (for example, different performance categories and
1571 cables with different nominal impedance) special precautions are required to ensure that they are properly identified

1572 **8.2.7 Physical dimensions**

1573 The requirements for the physical dimensions of connecting hardware at the telecommunications outlet are
1574 summarized in Table 53.

1575 **Table 53 – Connecting hardware requirements at the telecommunications outlet**

Characteristic	Requirement	Component or test standard
Category 5 unshielded	Mating dimensions and gauging	EN 60603-7-2
Category 5 shielded	Mating dimensions and gauging	EN 60603-7-3
Category 6 unshielded	Mating dimensions and gauging	EN 60603-7-4
Category 6 shielded	Mating dimensions and gauging	EN 60603-7-5
Category 7	Mating dimensions and gauging	EN 60603-7-7 ^a
^a In installations where other factors, such as Home Entertainment and Multimedia (HEM, see EN 50173-3) applications take preference over backward compatibility offered with EN 60603-7-7, also the interface specified in IEC/PAS 61076-3-104/Ed.1 (48B/1167/PAS) may be used.		

1576

1577 **8.3 Optical fibre connecting hardware**

1578 **8.3.1 General requirements**

1579 The requirements of 8.3.2 to 8.3.5 apply to all connecting hardware used to provide connections between
1580 optical fibre cables described in Clause 7. These requirements apply to the connecting hardware for both
1581 horizontal and backbone cabling. Additionally, all optical ports shall comply with the requirements of
1582 EN 60825-2.

1583 **8.3.2 Marking and colour coding**

1584 Coding of connectors and adapters, for example by colour, should be used to prevent accidental connection
1585 of different fibre types (i.e. singlemode, 50/125 µm or 62,5/125 µm multimode) and/or fibre categories. Consistent
1586 polarisation of duplex optical fibre connections shall be maintained throughout the cabling system by means
1587 of physical keying, administration (i.e. labelling) or both. Also, keying and the identification of fibre positions
1588 may be used to ensure that correct polarity is maintained for duplex links.

1589 The following colour code applies for IEC 60874-19-1 SC Duplex connectors:

1590 Multimode: beige or black

1591 Singlemode (physical contact): blue

1592 Singlemode (angled physical contact): green

1593 These markings are in addition to, and do not replace, other markings specified in EN 50174-1 or those
1594 required by local codes or regulations.

1595 **8.3.3 Mechanical and optical characteristics**

1596 Optical fibre connecting hardware shall meet the requirements of Table 54.

1597 **8.3.4 Telecommunications outlet requirements**

1598 The optical fibre cables in the work area shall be connected to the horizontal cabling with a duplex SC
1599 connector (SC-D) which meets the requirements of detail specification IEC 60874-19-1. The optical fibre
1600 connectors shall meet the requirements of 8.3.3.

1601 **8.3.5 Requirements for areas other than the telecommunications outlet**

1602 The optical fibre connectors used shall meet the requirements of 8.3.3, with exception of the physical
1603 dimensions as described in Table 54 b1).

1604 In areas other than the work area, the choice of connecting hardware is open to all types of optical fibre
1605 connectors standardized by IEC. When high density is an important consideration for the Campus Distributor
1606 (CD), Building Distributor (BD), Floor Distributor (FD), or Consolidation Point (CP), then Small Form Factor
1607 connector designs that accommodate at least two fibres within the footprint of an EN 60603-7 connector are
1608 recommended.

1609 However, where detail specifications produced by IEC or CENELEC in accordance with requirements of
1610 Table 54 a) do not exist then assurance should be sought from suppliers that the combinations of
1611 components within connecting hardware are able to meet the optical and mechanical requirements of this
1612 clause.

1613

Table 54 - Mechanical and optical characteristics of optical fibre connecting hardware

	Characteristic		Requirement	Reference
a)	Optical performance characteristics			
	Maximum attenuation	connectors	0,5 dB for 95% of matings 0,75 dB for 100 % of matings	EN 61300-3-34
		splice	0,3 dB	EN 61073-1
	Minimum return loss	multimode	20 dB	Method 1 of EN 61300-3-6:1997
		singlemode	35 dB	Method 1 or 2 of EN 61300-3-6:1997
b)	Physical characteristics			
b1)	Physical dimensions (only at telecommunications outlet for multimode optical fibre)		Mating dimensions and gauging	IEC 60874-19-1 (SC-D)
b2)	Cable termination compatibility			
	Nominal cladding diameter (µm)		125	4.1.1.4 (A1a, A1b) and 5.1.4 (B1) of IEC 60793-2:1998
	Nominal buffer diameter (µm)		-	6.1 of IEC 60794-2:1989
	Cable outer diameter (µm)		-	6.1 of IEC 60794-2:1989
c)	Mechanical characteristics			
	Mechanical endurance (durability) cycles		≥ 500 (see NOTE 1)	EN 61300-2-2
	Strength of coupling mechanism		40 N 1 min (see NOTE 1)	EN 61300-2-6
	Cable pulling		50 N 1 min (see NOTE 2)	EN 61300-2-4
	Connector side pull		5 N 1 min (see NOTE 1)	EN 61300-2-42
d)	Environmental Performance Requirements			
	Cold		-10°C, 96 h (see NOTE 1)	EN 61300-2-17
	Dry Heat		60°C, 96 h (see NOTE 1)	EN 61300-2-18
	Damp heat (steady state)		40°C 93% RH, 96 h (see NOTE 1)	EN 61300-2-19
	Impact		1,5 m, 5 times (see NOTE 3)	EN 61300-2-12
	Vibration		10 Hz to 55 Hz, 0,75 mm, 30 min at each of 3 directions (see NOTE 1)	EN 61300-2-1
	Change of temperature test		+60°C/-10°C , rate 1deg/min, 30 min at extremes, 5 cycles (see NOTE 1)	EN 61300-2-22
NOTE 1 Max change during test < 0,2 dB, initial and final attenuation < 0,75 dB				
NOTE 2 Initial and final attenuation < 0,75 dB				
NOTE 3 Max change during test < 0,5 dB, initial and final attenuation < 0,75 dB				

1614

1615 **9 Requirements for cords and jumpers**

1616 **9.1 General**

1617 The performance of channels is dependent upon the performance of cords and jumper cables. The moves,
1618 additions and changes made using cords and jumpers represents a greater risk to operational channel
1619 performance than that of installed horizontal or backbone cables.

1620 This clause defines the requirements for terminated cables used as work area cords, CP cords, equipment
1621 cords and patch cords within horizontal and backbone cabling. Jumpers shall be in accordance with the
1622 requirements of Clause 7.

1623 **9.2 Balanced cords**

1624 **9.2.1 General**

1625 This subclause specifies the minimum requirements for balanced cords used to form the horizontal and
1626 backbone channels specified in Clause 4.

1627 A cord shall be assembled in accordance with 7.2.

1628 Work area cords shall only be assembled using flexible cables of stranded construction as defined in 7.2.

1629 Connections used shall meet the requirements of Clause 8 with the exception of the equipment connectors
1630 used on work area and equipment cords that lie outside the scope of this standard.

1631 The cable shall be fitted to the connections following the procedures and using the tools specified by the
1632 manufacturers of the connections. Where screened cables and connections are used, the cable screen shall
1633 be connected according to the connections manufacturers' instruction.

1634 The connections and the interconnected pin assignment shall be in accordance with the intended use of the
1635 cord and shall be a logical extension to the cabling interface(s) to which it is to be connected.

1636 **9.2.2 Cable attenuation**

1637 The maximum insulated conductor diameter for use within modular plugs according to EN 60603-7 is
1638 1,02 mm. For cables containing stranded conductors the insulated conductor diameter influences the
1639 maximum conductor diameter for a given cable construction which in turn affects the attenuation of the cable.

1640 The maximum attenuation ratio of flexible cables in accordance with 7.2, defined as their attenuation /
1641 insertion loss (dB/100 m) compared to that of installation cables, is 1,5. However, cable constructions having
1642 attenuation ratios below 1,5 are supported by the reference implementation rules of Clause 6.

1643 The maintenance of channel performance requires that flexible cables of the correct attenuation ratio shall be
1644 used as defined by the implementation rules.

1645 **9.2.3 Electrical performance requirements for patch cords**

1646 **9.2.3.1 Insertion loss**

1647 Insertion loss measurements of cords shall not exceed the insertion loss requirements of the connection at
1648 each end, plus the insertion loss requirement for the cable, scaled for length. The insertion loss performance
1649 is achieved by design.

1650 **9.2.3.2 Return loss**

1651 Cords shall meet the return loss requirements specified in Table 55 when measured in accordance with
1652 EN 61935-2.

1653

Table 55 – Return loss requirements for cords

Category	Frequency MHz	Minimum return loss dB
5	$4 \leq f < 25$	$19,8+3 \cdot \log f$
	$25 \leq f \leq 100$	$38-10 \cdot \log f$
6	$4 \leq f < 25$	$19,8+3 \cdot \log f$
	$25 \leq f \leq 250$	$38-10 \cdot \log f$
7	$4 \leq f < 25$	$19,8+3 \cdot \log f$
	$25 \leq f \leq 600$	$38-10 \cdot \log f$

1654

1655 **9.2.3.3 Near-end crosstalk loss (NEXT)**

1656 The cords for Category 5 shall meet the requirements calculated according to equation (6) when measured in
1657 accordance with EN 61935-2.

1658
$$\alpha_{NEXT, cord}(L) = 10 \log_{10} \left(10^{\frac{-\alpha_{NEXT, con}}{10}} + 10^{\left(\frac{-\alpha_{NEXT, cab} + 2 \cdot \alpha_{con}}{10} \right)} \right) + RSXT \quad (6)$$

1659 where

1660 $\alpha_{NEXT, cord}(L)$ NEXT of the entire cord in dB

1661 $\alpha_{NEXT, con}$ NEXT of the connectors in dB

1662 $\alpha_{NEXT, cab}$ NEXT of the cable itself in dB

1663 α_{con} attenuation of one connector in dB

1664 $RSXT$ reflected signal crosstalk ($RSXT = 0$ dB for Category 5 cords, $RSXT = 0,5$ dB for Category 6 and
1665 Category 7 cords)

1666 The NEXT of the connectors is determined by equation (7):

1667
$$\alpha_{NEXT, con} = -20 \cdot \log_{10} \left(10^{\frac{-\alpha_{NEXT, local}}{20}} + 10^{\left(\frac{-\alpha_{NEXT, remote} + 2 \cdot (\alpha_L + \alpha_{con})}{20} \right)} \right) \quad (7)$$

1668 where

1669 $\alpha_{NEXT, local}$ NEXT of the connector at the local end of the cord in dB

1670 $\alpha_{NEXT, remote}$ NEXT of the connector at the remote end of the cord in dB

1671 α_L length corrected attenuation of the cable in dB

1672 α_{con} attenuation of the connector in dB

1673 The length corrected attenuation of the cable is given by equation (8):

$$1674 \quad \alpha_L = \alpha_{cab} \cdot \frac{L}{100} \quad (8)$$

1675 where

1676 L length of the cable in the cord

1677 α_{cab} attenuation of 100 m of the cable used for the cord

1678 The frequency dependence of NEXT, if the anchor value at 100 MHz is known, is given by equation (9):

$$1679 \quad \alpha_{NEXT,local} = \alpha_{NEXT,remote} = \alpha_{NEXT,con}(100) - 20 \cdot \log_{10} \left(\frac{f}{100} \right) \quad (9)$$

1680 where

1681 $\alpha_{NEXT,con}(100)$ NEXT of the connector in dB at 100 MHz

1682 The length corrected NEXT of the cable of the cord is given by equation (10):

$$1683 \quad \alpha_{NEXT,cab}(L) = \alpha_{NEXT,cab} - 10 \cdot \log_{10} \left(\frac{1 - 10^{-\frac{\alpha_L}{5}}}{1 - 10^{-\frac{\alpha_{cab}}{5}}} \right) \quad (10)$$

1684 Calculations yielding NEXT limits in excess of 65 dB shall revert to a limit of 65 dB.

1685 Requirements for Category 6 and 7 cords are for further study. Table 56 lists informative NEXT values at key
1686 frequencies for different lengths of the cords.

1687 **Table 56 - Informative values of NEXT at key frequencies**
1688 **for Category 5, 6 and 7 cords**

Frequency MHz	NEXT for cord of Category dB								
	5			6			7		
	Length			Length			Length		
	2 m	5 m	10 m	2 m	5 m	10 m	2 m	5 m	10 m
1	65,0	65,0	65,0	65,0	65,0	65,0	65,0	65,0	65,0
16	50,3	49,5	48,7	61,6	60,0	58,5	65,0	65,0	65,0
100	35,0	34,7	34,5	46,2	45,0	44,2	65,0	65,0	65,0
250	N/A			38,6	37,9	37,6	60,7	61,2	61,9
600				N/A			55,4	56,2	57,0

1689 For the commonly available Category 5 test head the anchor value at 100 MHz is:

$$1690 \quad \alpha_{NEXT,con}(100) = 41,0 \text{ dB} \quad (11)$$

1691 **9.2.4 Identification**

1692 Each cord shall be identified to indicate:

- 1693 a) length;
- 1694 b) the design attenuation ratio of the cable;
- 1695 c) category of cable;
- 1696 d) wire-map status where a direct pin-pin relationship does not exist (i.e. cross-over cords).

1697 **9.3 Optical fibre cords**

1698 This subclause specifies the minimum requirements for optical fibre cords used to form the horizontal and
1699 backbone cabling channels specified in Clause 4.

1700 Optical fibre cables used for cords shall meet the generic specification EN 60794-1-1, the test methods
1701 EN 60794-1-2 and the sectional specifications as defined in 7.4.

1702 Connecting hardware used shall meet the requirements of Clause 8 with the exception of the equipment
1703 connectors used on work area and equipment cords that lie outside the scope of this standard. The cable shall be
1704 fitted to the connections following the procedures and using the tools specified by the manufacturers of the
1705 connections. The connecting hardware and the means of maintaining polarity within the cord shall be in
1706 accordance with the intended use of the cord and shall be a logical extension to the cabling interface(s) to which it
1707 is to be connected.

Draft for comment

1708 **Annex A**
 1709 (normative)

1710 **Link performance limits**

1711 **A.1 General**

1712 This annex contains performance requirement formulae for permanent links and CP links as shown in
 1713 Figure A.1.

1714 The cabling under test in Configurations A, B and C is termed the permanent link:

1715 a) Configurations A and B comprise fixed cabling only.

1716 b) Configuration C comprises fixed cabling and a CP cord. Measurements made for this configuration are
 1717 invalid if the CP cord is changed.

1718 The cabling under test in Configuration D contains fixed cabling only and is termed the CP link.

1719 In all configurations the test configuration reference plane of a link is within the test cord cable next to, and
 1720 including, the test cord connection which mates to the termination point of the link under test.

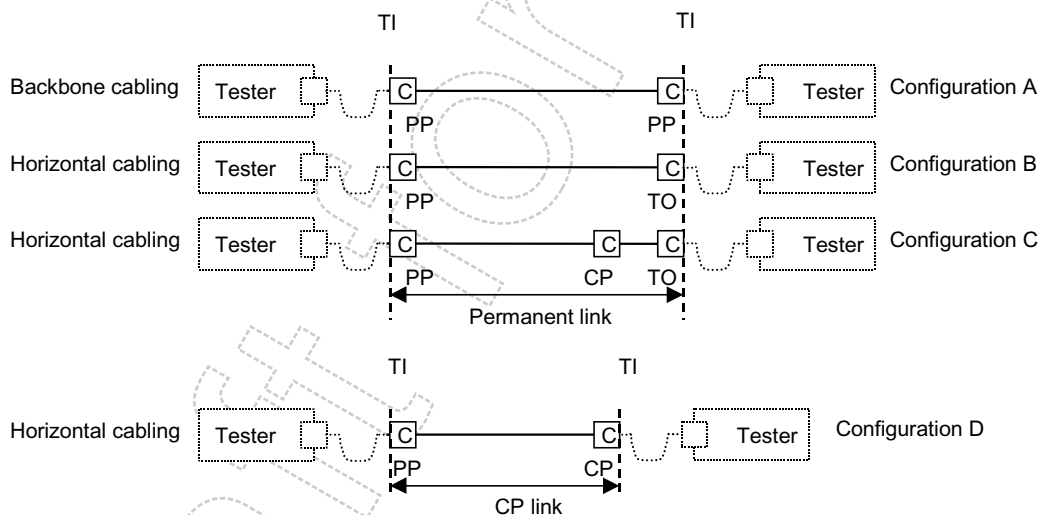

1721

1722 **Figure A.1 - Link options**

1723 **A.2 Balanced cabling**

1724 **A.2.1 General**

1725 This clause contains performance requirement formulae for installed balanced cabling links. Annex B
 1726 contains values derived from the formulae at key frequencies for permanent links and is for information only.

1727 The parameters specified in this Annex apply to balanced permanent links and CP links with screened or
 1728 unscreened cable elements, with or without an overall screen, unless explicitly stated otherwise.

1729 The nominal impedance of links is 100 Ω . This is achieved by suitable design, and appropriate choice of cabling
 1730 components (irrespective of their nominal impedance). The link performance specification of the relevant Class
 1731 shall be met for all temperatures at which the cabling is intended to operate.

1732 Consideration should be given to measuring performance at worst case temperatures, or calculating worst
 1733 case performance based on measurements made at other temperatures.

1734 NOTE The term “attenuation” is used in A.2.2 and A.2.3 since it is common usage within the cabling industry. However, the correct term
 1735 is insertion loss which includes the effect of impedance variations both with and between the cabling components in the link.

1736 **A.2.2 Link limits**

1737 **A.2.2.1 Return loss**

1738 The return loss of each pair of the link shall meet or exceed the limits computed, to one decimal place, using
 1739 the formulae of Table A.1. The return loss shall be measured according to 5.4.2.

1740 **Table A.1 - Formulae for return loss limits for a link**

Class	Frequency MHz	Minimum return loss dB
C	$1 \leq f \leq 16$	15,0
D	$1 \leq f < 20$	19,0
	$20 \leq f \leq 100$	$32 - 10 \cdot \log(f)$
E	$1 \leq f < 10$	21,0
	$10 \leq f < 40$	$26 - 5 \cdot \log(f)$
	$40 \leq f \leq 250$	$34 - 10 \log(f)$
F	$1 \leq f < 10$	21,0
	$10 \leq f < 40$	$26 - 5 \cdot \log(f)$
	$40 \leq f < 251,2$	$34 - 10 \cdot \log(f)$
	$251,2 \leq f \leq 600$	10,0

1741
 1742 For all configurations of Figure A.1, values of return loss at frequencies for which the measured attenuation is
 1743 below 3,0 dB are for information only.

1744 **A.2.2.2 Attenuation / Insertion loss**

1745 Where the maximum lengths of channel components to be added to the link are unknown, the attenuation of
 1746 each pair of the link shall not exceed the limits computed, to one decimal place, using the formulae of
 1747 Table A.2. See 5.4.3 for details of measurement.

1748

Table A.2 - Formulae for attenuation limits for a link

Link Class	Frequency MHz	Maximum attenuation dB
A	$f = 0,1$	16,0
B	$f = 0,1$	5,5
	$f = 1$	5,8
C	$1 \leq f \leq 16$	$0,9 \cdot (3,23\sqrt{f}) + 3 \cdot 0,2$
D	$1 \leq f \leq 100$	$(L/100) \cdot (1,9108\sqrt{f} + 0,0222 \cdot f + 0,2/\sqrt{f}) + n \cdot 0,04 \cdot \sqrt{f}$, 4,0 min.
E	$1 \leq f \leq 250$	$(L/100) \cdot (1,82\sqrt{f} + 0,0169 \cdot f + 0,25/\sqrt{f}) + n \cdot 0,02 \cdot \sqrt{f}$, 4,0 min.
F	$1 \leq f \leq 600$	$(L/100) \cdot (1,8\sqrt{f} + 0,01 \cdot f + 0,2/\sqrt{f}) + n \cdot 0,02 \cdot \sqrt{f}$, 4,0 min.
Where	$L = L_{FC} + L_{CP} \cdot Y$ L_{FC} length of fixed cable (m) L_{CP} length of CP cord (where present) (m) Y ratio of CP cable attenuation (dB/m) to fixed horizontal cable attenuation (dB/m) (see Clause 9) $n = 2$ for Configurations A, B and D $n = 3$ for Configuration C	

1749 Where the maximum lengths of channel components to be added to the link are known and specified for the
 1750 cabling, the margin between the measured value of attenuation/insertion loss of the link and the channel limits of
 1751 Table 4 shall exceed the total attenuation/insertion loss of

- 1752 a) the specified maximum lengths of cords used to create the channel,
- 1753 b) the specified maximum lengths of any additional cables and connections, where appropriate, used to create
 1754 the channel.

1755 A.2.2.3 NEXT

1756 A.2.2.3.1 Pair-to-pair NEXT

1757 The NEXT between each pair combination of the link shall meet or exceed the limits computed, to one
 1758 decimal place, using the formulae of Table A.3. The NEXT shall be measured according to 5.4.4.1.

1759

Table A.3 - Formulae for NEXT limits for a link

Link Class	Frequency MHz	Minimum NEXT dB
A	$f \leq 0,1$	27,0
B	$0,1 \leq f \leq 1$	$25,0 - 15 \cdot \log(f)$
C	$1 \leq f \leq 16$	$40,1 - 15,8 \cdot \log(f)$
D	$1 \leq f \leq 100$	$- 20 \log \left(10^{\frac{65,3 - 15 \log(f)}{- 20}} + 10^{\frac{83 - 20 \log(f)}{- 20}} \right), 60,0 \text{ max.}$
E	$1 \leq f \leq 250$	$- 20 \log \left(10^{\frac{74,3 - 15 \log(f)}{- 20}} + 10^{\frac{94 - 20 \log(f)}{- 20}} \right), 65,0 \text{ max}$
F	$1 \leq f \leq 600$	$- 20 \log \left(10^{\frac{102,4 - 15 \log(f)}{- 20}} + 10^{\frac{102,4 - 15 \log(f)}{- 20}} \right), 65,0 \text{ max.}$

1760

1761 Values of NEXT at frequencies for which the measured link attenuation is below 4,0 dB are for information
1762 only.

1763 **A.2.2.3.2 Power sum NEXT (PSNEXT)**

1764 The PSNEXT for each pair of the link shall meet or exceed the limits computed, to one decimal place, using
1765 the formulae of Table A.4. The PSNEXT shall be measured according to 5.4.4.2.

1766

Table A.4 - Formulae for PSNEXT limits for a link

Link Class	Frequency MHz	Minimum PSNEXT dB
D	$1 \leq f \leq 100$	$- 20 \log \left(10^{\frac{62,3 - 15 \log(f)}{- 20}} + 10^{\frac{80 - 20 \log(f)}{- 20}} \right), 57,0 \text{ max.}$
E	$1 \leq f \leq 250$	$- 20 \log \left(10^{\frac{72,3 - 15 \log(f)}{- 20}} + 10^{\frac{90 - 20 \log(f)}{- 20}} \right), 62,0 \text{ max}$
F	$1 \leq f \leq 600$	$- 20 \log \left(10^{\frac{99,4 - 15 \log(f)}{- 20}} + 10^{\frac{99,4 - 15 \log(f)}{- 20}} \right), 62,0 \text{ max.}$

1767

1768 Values of PSNEXT at frequencies for which the measured link attenuation is below 4,0 dB are for information
1769 only.

1770 **A.2.2.4 Attenuation to crosstalk loss ratio (ACR)**1771 **A.2.2.4.1 Pair-to-pair ACR**

1772 The ACR for each pair combination of the link shall meet or exceed the limits calculated from the relevant
1773 NEXT and attenuation/insertion loss formulae.

1774 **A.2.2.4.2 Power sum ACR (PSACR)**

1775 The PSACR for each pair combination of the link shall meet or exceed the limits calculated from the relevant
1776 PSNEXT and attenuation/insertion loss formulae.

1777 **A.2.2.5 ELFEXT**1778 **A.2.2.5.1 Pair-to-pair ELFEXT**

1779 The ELFEXT for each pair of the link shall meet or exceed the limits computed, to one decimal place, using
1780 the formulae of Table A.5. The ELFEXT shall be measured according to 5.4.6.1.

1781 **Table A.5 - Formulae for ELFEXT limits for a link**

Class	Frequency MHz	Minimum ELFEXT dB
D	$1 \leq f \leq 100$	$-20 \log \left(10^{\frac{63,8 - 20 \log(f)}{-20}} + n \cdot 10^{\frac{75,1 - 20 \log(f)}{-20}} \right)$
E	$1 \leq f \leq 250$	$-20 \log \left(10^{\frac{67,8 - 20 \log(f)}{-20}} + n \cdot 10^{\frac{83,1 - 20 \log(f)}{-20}} \right)$
F	$1 \leq f \leq 600$	$-20 \log \left(10^{\frac{94 - 20 \log(f)}{-20}} + n \cdot 10^{\frac{90 - 15 \log(f)}{-20}} \right), 65,0 \text{ max.}$
Where $n = 2$ for Configurations A, B and D $n = 3$ for Configuration C		

1782

1783 **A.2.2.5.2 Power sum ELFEXT (PSELFEXT)**

1784 The PSELFEXT for each pair of the link shall meet or exceed the limits computed, to one decimal place,
1785 using the formulae of Table A.6. The PSELFEXT shall be measured according to 5.4.6.2.

1786

Table A.6 - Formulae for PSELFEXT limits for a link

Class	Frequency MHz	Minimum PSELFEXT dB
D	$1 \leq f \leq 100$	$-20 \log \left(10^{\frac{60,8 - 20 \log(f)}{-20}} + n \cdot 10^{\frac{72,1 - 20 \log(f)}{-20}} \right)$
E	$1 \leq f \leq 250$	$-20 \log \left(10^{\frac{64,8 - 20 \log(f)}{-20}} + n \cdot 10^{\frac{80,1 - 20 \log(f)}{-20}} \right)$
F	$1 \leq f \leq 600$	$-20 \log \left(10^{\frac{91 - 20 \log(f)}{-20}} + n \cdot 10^{\frac{87 - 15 \log(f)}{-20}} \right), 62,0 \text{ max.}$
Where		$n = 2$ for Configurations A, B and D $n = 3$ for Configuration C

1787

1788 A.2.2.6 Direct current (d.c.) loop resistance

1789 Where the maximum lengths of channel components to be added to the link are unknown, the d.c. loop
1790 resistance of each pair of the link shall be less than the values given in Table A.7 for each Class of
1791 application. See 5.4.7 for details of measurement.

1792

Table A.7 – Direct current (d.c.) loop resistance limits for a link

Link Class	Maximum d.c. loop resistance Ω
A	530
B	140
C	34
D	$(L/100) \cdot 22 + n \cdot 0,4$
E	$(L/100) \cdot 22 + n \cdot 0,4$
F	$(L/100) \cdot 22 + n \cdot 0,4$
Where	
$L = L_{FC} + L_{CP} \cdot Y$	
L_{FC} length of fixed cable (m)	
L_{CP} length of CP cord (where present) (m)	
Y ratio of CP cable attenuation (dB/m) to fixed horizontal cable attenuation (dB/m) (see Clause 9)	
$n = 2$ for Configurations A, B and D	
$n = 3$ for Configuration C	

1793 Where the maximum lengths of channel components to be added to the link are known and specified for the
1794 cabling, the margin between the measured value of d. c. loop resistance of the link and the channel limits of
1795 Table 16 shall exceed the total d. c. loop resistance of

- 1796 a) the specified maximum lengths of cords used to create the channel,
- 1797 b) the specified maximum lengths of any additional cables and connections, where appropriate, used to create
1798 the channel.

1799 This requirement is considered to be met if the equivalent requirements of A.2.2.2 (attenuation/insertion loss) and
1800 A.2.2.9 (delay skew) are also met.

1801 A.2.2.7 Direct current (d.c.) resistance unbalance

1802 The d.c. resistance unbalance of the conductors within a pair shall not exceed 3 %.

1803 A.2.2.8 Propagation delay

1804 Where the maximum lengths of channel components to be added to the link are unknown, the maximum
1805 propagation delay of each pair in the link shall not exceed the limits computed, to three decimal places, using
1806 the formulae of Table A.8. See 5.4.10 for details of measurement.

1807 **Table A.8 - Propagation delay formulae for a link**

Link Class	Frequency MHz	Maximum propagation delay μs
A	$f = 0,1$	19,400
B	$f \leq 1$	4,400
C	$1 \leq f \leq 16$	$(L/100) \cdot (0,534 + 0,036/\sqrt{f}) + n \cdot 0,0025$
D	$1 \leq f \leq 100$	$(L/100) \cdot (0,534 + 0,036/\sqrt{f}) + n \cdot 0,0025$
E	$1 \leq f \leq 250$	$(L/100) \cdot (0,534 + 0,036/\sqrt{f}) + n \cdot 0,0025$
F	$1 \leq f \leq 600$	$(L/100) \cdot (0,534 + 0,036/\sqrt{f}) + n \cdot 0,0025$
Where $L = L_{FC} + L_{CP} \cdot Y$ L_{FC} length of fixed cable (m) L_{CP} length of CP cord (where present) (m) Y ratio of CP cable attenuation (dB/m) to fixed horizontal cable attenuation (dB/m) (see Clause 9) $n = 2$ for Configurations A, B and D $n = 3$ for Configuration C		

1808 Where the maximum lengths of channel components to be added to the link are known and specified for the
1809 cabling, the margin between the measured value propagation delay of the link and the channel limits of Table 17
1810 shall exceed the total propagation delay of

1811 a) the specified maximum lengths of cords used to create the channel,

1812 b) the specified maximum lengths of any additional cables and connections, where appropriate, used to create
1813 the channel.

1814 This requirement is considered to be met if the equivalent requirements of A.2.2.2 (attenuation/insertion loss) and
1815 A.2.2.9 (delay skew) are also met.

1816 A.2.2.9 Delay skew

1817 Where the maximum lengths of channel components to be added to the link are unknown, the maximum
1818 delay skew between the pairs in the link shall not exceed the limits computed, to three decimal places, using
1819 the formulae of Table A.9. See 5.4.11 for details of measurement.

1820

Table A.9 - Delay skew formulae for a link

Link Class	Frequency MHz	Maximum delay skew μs
C	$1 \leq f \leq 16$	$(L/100) \cdot 0,045 + n \cdot 0,001\ 25$
D	$1 \leq f \leq 100$	$(L/100) \cdot 0,045 + n \cdot 0,001\ 25$
E	$1 \leq f \leq 250$	$(L/100) \cdot 0,045 + n \cdot 0,001\ 25$
F	$1 \leq f \leq 600$	$(L/100) \cdot 0,045 + n \cdot 0,001\ 25$
Where $L = L_{FC} + L_{CP}$ L_{FC} length of fixed cable (m) L_{CP} length of CP cord (where present) (m) $n = 2$ for Configurations A, B and D $n = 3$ for Configuration C		

1821 Where the maximum lengths of channel components to be added to the link are known and specified for the
 1822 cabling, the margin between the measured value of delay skew of the link and the channel limits of Table 19 shall
 1823 exceed the total delay skew of

- 1824 a) the specified maximum lengths of cords used to create the channel,
- 1825 b) the specified maximum lengths of any additional cables and connections, where appropriate, used to create
 1826 the channel.

1827 **A.3 Optical fibre cabling**

1828 The attenuation of a link at a specified wavelength shall not exceed the sum of the specified attenuation
 1829 values for the cabling components at that wavelength (where the attenuation of a length of optical fibre cable
 1830 is calculated from its attenuation coefficient multiplied by its length).

1831 Measurements made shall be consistent with the design values of cable length and cabling materials used.

1832 The attenuation of a link shall be measured according to

- 1833 a) Annex A.3.2 (Method 1) of EN 50346:2002 for multimode optical fibre,
- 1834 b) method 1.A of EN 61280-4-2:1999 for singlemode optical fibre.

1835 NOTE The test methods have been developed for conventional optical fibre connection systems comprising two plugs and an adaptor.
 1836 In some cases the methods are not appropriate for Small Form Factor connectors that comprise a plug and socket.

1837

Annex B

1838

(informative)

1839

Permanent link performance limits for maximum implementation

1840

B.1 General

1841

The values shown in Tables B.1 to B.12 are derived from the formulae in Annex A at key frequencies.

1842

Where relevant, the values of L , Y and n are: $L = 90$, $Y = 1$ and $n = 3$.

1843

B.2 Performance limits

1844

B.2.1 Return loss

1845

Table B.1 - Return loss limits for a permanent link at key frequencies

Frequency MHz	Minimum return loss dB			
	Class C	Class D	Class E	Class F
1,0	15,0	19,0	21,0	21,0
16,0	15,0	19,0	20,0	20,0
100,0	N/A	12,0	14,0	14,0
250,0	N/A	N/A	10,0	10,0
600,0	N/A	N/A	N/A	10,0

1846

1847

B.2.2 Attenuation / insertion loss

1848

Table B.2 - Attenuation limits for a permanent link at key frequencies

Frequency MHz	Maximum attenuation dB					
	Class A	Class B	Class C	Class D	Class E	Class F
0,1	16,0	5,5	N/A	N/A	N/A	N/A
1,0	N/A	5,8	4,0	4,0	4,0	4,0
16,0	N/A	N/A	12,2	7,7	7,1	6,9
100,0	N/A	N/A	N/A	20,4	18,5	17,7
250,0	N/A	N/A	N/A	N/A	30,7	28,8
600,0	N/A	N/A	N/A	N/A	N/A	46,6

1849

1850 **B.2.3 Near end crosstalk loss**

1851 **Table B.3 - NEXT limits for a permanent link at key frequencies**

Frequency MHz	Minimum NEXT dB					
	Class A	Class B	Class C	Class D	Class E	Class F
0,1	27,0	40,0	N/A	N/A	N/A	N/A
1,0	N/A	25,0	40,1	60,0	65,0	65,0
16,0	N/A	N/A	21,1	45,2	54,6	65,0
100,0	N/A	N/A	N/A	32,3	41,8	65,0
250,0	N/A	N/A	N/A	N/A	35,3	60,4
600,0	N/A	N/A	N/A	N/A	N/A	54,7

1852

1853 **B.2.4 Power sum NEXT**

1854 **Table B.4 - PSNEXT limits for a permanent link at key frequencies**

Frequency MHz	Minimum PSNEXT dB		
	Class D	Class E	Class F
1,0	57,0	62,0	62,0
16,0	42,2	52,2	62,0
100,0	29,3	39,3	62,0
250,0	N/A	32,7	57,4
600,0	N/A	N/A	51,7

1855

1856 **B.2.5 Attenuation to crosstalk ratio**

1857 **Table B.5 - ACR limits for a permanent link at key frequencies**

Frequency MHz	Minimum ACR dB		
	Class D	Class E	Class F
1,0	56,0	61,0	61,0
16,0	37,5	47,5	58,1
100,0	11,9	23,3	47,3
250,0	N/A	4,7	31,6
600,0	N/A	N/A	8,1

1858

1859 **B.2.6 Power sum ACR**1860 **Table B.6 - PSACR limits for a permanent link at key frequencies**

Frequency MHz	Minimum PSACR dB		
	Class D	Class E	Class F
1,0	53,0	58,0	58,0
16,0	34,5	45,1	55,1
100,0	8,9	20,8	44,3
250,0	N/A	2,0	28,6
600,0	N/A	N/A	5,1

1861

1862 **B.2.7 ELFEXT**1863 **Table B.7 - ELFEXT limits for a permanent link at key frequencies**

Frequency MHz	Minimum ELFEXT dB		
	Class D	Class E	Class F
1,0	58,6	64,2	65,0
16,0	34,5	40,1	59,3
100,0	18,6	24,2	46,0
250,0	N/A	16,2	39,2
600,0	N/A	N/A	32,6

1864

1865 **B.2.8 Power sum ELFEXT**1866 **Table B.8 - PSELFEXT limits for a permanent link at key frequencies**

Frequency MHz	Minimum PSELFEXT dB		
	Class D	Class E	Class F
1,0	55,6	61,2	62,0
16,0	31,5	37,1	56,3
100,0	15,6	21,2	43,0
250,0	N/A	13,2	36,2
600,0	N/A	N/A	29,6

1867

1868 **B.2.9 Direct current (d.c.) loop resistance**

1869 **Table B.9 – Direct current (d.c.) loop resistance limits for a permanent link at key frequencies**

Maximum d.c. loop resistance Ω					
Link Class A	Link Class B	Link Class C	Link Class D	Link Class E	Link Class F
530	140	34	21	21	21

1870

1871 **B.2.10 Direct current (d.c.) resistance unbalance**

1872 The d.c. resistance unbalance of the conductors within a pair shall not exceed 3 %.

1873 **B.2.11 Propagation delay**

1874 **Table B.10 - Propagation delay limits for a permanent link at key frequencies**

Frequency MHz	Maximum propagation delay μs					
	Class A	Class B	Class C	Class D	Class E	Class F
0,1	19,400	4,400	N/A	N/A	N/A	N/A
1,0	N/A	4,400	0,521	0,521	0,521	0,521
16,0	N/A	N/A	0,496	0,496	0,496	0,496
100,0	N/A	N/A	N/A	0,491	0,491	0,491
250,0	N/A	N/A	N/A	N/A	0,490	0,490
600,0	N/A	N/A	N/A	N/A	N/A	0,489

1875

1876 **B.2.12 Delay skew**

1877 **Table B.11 - Delay skew limits for a permanent link at key frequencies**

Link Class	Frequency MHz	Maximum delay skew μs
C	$1 \leq f \leq 16$	0,044
D	$1 \leq f \leq 100$	0,044
E	$1 \leq f \leq 250$	0,044
F	$1 \leq f \leq 600$	0,026

1878

1879

Annex C

1880

(informative)

1881

Class F channel and permanent link with two connections

1882

Most class F channels and permanent links are implemented with two connections only.

1883 The performance limits for balanced cabling channels given in this annex supplement Table 10 and Table 11
 1884 in 5.4.5; they are derived from the component performance limits of clause 7 and clause 8 assuming the
 1885 channel is composed of 90 m of solid conductor cable, 10 m of cord(s) and two connections (see Figure C.1).

1886 The performance limits for balanced cabling permanent links given in this annex supplement A.2.2.4; they are
 1887 derived from the component performance limits of clause 7 and clause 8 assuming the permanent link is
 1888 composed of 90 m of solid conductor cable and two connections (see Figure C.1).

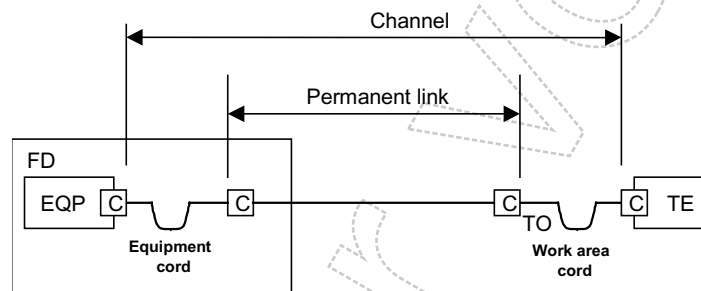

1889

Figure C.1 – Two connection channel and permanent link

1890

1891 The ACR of each pair combination of a channel and of a permanent link are given in Table C.1.

1892 The PSACR of each pair of a channel and of a permanent link are also given in Table C.1.

1893

Table C.1 - ACR and PSACR values for 2 connection class F channels and permanent links at key frequencies

1894

Frequency MHz	Channel		Permanent link	
	Minimum ACR dB	Minimum PSACR dB	Minimum ACR dB	Minimum PSACR dB
1,0	61,0	58,0	61,0	58,0
16,0	57,1	54,1	58,2	55,2
100,0	44,6	41,6	47,5	44,5
250,0	27,3	24,3	31,9	28,9
600,0	1,1	-1,9	8,6	5,6

1895	Annex D
1896	(normative)
1897	Mechanical and environmental performance testing of balanced cabling connecting hardware of types other than those used at the TO
1898	
1899	D.1 Introduction
1900	The mechanical and environmental performance of connecting hardware is vital to the cabling system.
1901	Changes in contact resistance because of operational and environmental stress can negatively affect the
1902	transmission characteristics of the cabling system. Product life testing is accomplished by subjecting the
1903	product to a number of mechanical and environmental conditions and measuring any resistance deviations at
1904	prescribed intervals and after completion of each conditioning sequence. In addition, the product shall not
1905	show evidence of degradation with respect to the ease of mechanical termination, safety or other functional
1906	attributes at any time during or after environmental conditioning.
1907	To ensure that all connecting hardware for balanced cabling systems will perform reliably under field
1908	installation conditions, it shall be capable of maintaining reliable connections throughout the series of
1909	environmental conditioning and testing illustrated in Table D.2 to Table D.5. Products under test shall be
1910	mounted and connected in accordance with manufacturer's guidelines. Unless otherwise specified, tests
1911	should be carried out under standard atmospheric conditions in accordance with 5.3.1 of EN 60068-1.
1912	NOTE This annex provides mechanical connection performance requirements for connections that are not covered by a specific IEC or
1913	CENELEC connector standard. It is intended to replace the specifications in this annex by reference to European standards, as they
1914	become available.
1915	D.2 Test requirements
1916	D.2.1 General
1917	This test schedule shows all tests and the order in which they shall be carried out, as well as the
1918	requirements to be met.
1919	Unless otherwise specified, connecting hardware shall be tested in the mated or terminated state. Care shall
1920	be taken to keep a particular combination of connecting hardware together during the complete test
1921	sequence. That is, when unmating is necessary for a certain test, the same connecting hardware shall be
1922	mated for the subsequent tests.
1923	Hereinafter, mated/terminated connecting hardware is called the "specimen".
1924	For each group, a minimum of 10 product samples shall be used to compile data for supporting a conclusion
1925	that pass criteria are satisfied.

1926 **D.2.2 Initial test measurements**

1927 All specimens shall be subjected to the measurements and sequence shown in Table D.1.

1928 **Table D.1 - Test group P**

Test phase	Test			Measurement to be performed		
	Title	EN 60512 Test No.	Severity or condition of test	Title	EN 60512 Test No.	Requirements
P 1	General examination	1		Visual examination	1a	There shall be no defects that would impair normal operation
				Examination of dimensions and mass	1b	The dimensions shall comply with those specified in the detail specification
P 2	Polarization (if applicable)					
P 3	Contact resistance		All signal contacts and screen / specimens (bulk resistance subtracted)	Millivolt level method	2a	Contact resistance $\leq 20 \text{ m}\Omega$
P 4			Test voltage DC (100 V \pm 15 V) Method A Mated or terminated connectors	Insulation resistance	3a	$\geq 500 \text{ M}\Omega$
P 5			Contact/contact Method A Mated or terminated connectors	Voltage proof	4a	DC 1 000 V or AC 1 000 V (peak)
			All contacts to screen: Method A Mated or terminated connectors			DC 1 500 V or AC 1 500 V (peak)

1929

1930 **D.2.3 Environmental and mechanical performance**1931 The specimens shall be divided into four groups: group A, group B, group C and group D. Connecting
1932 hardware in each group shall undergo the tests specified in the relevant group.

1933

Table D.2 - Test group AP

Test phase	Test			Measurement to be performed		
	Title	EN 60512 Test No.	Severity or condition of test	Title	EN 60512 Test No.	Requirements
AP 1	Insertion and withdrawal forces (two piece connectors)	13b	Connector locking device depresseded (if applicable)			As per manufacturer's specifications
AP 2	Effectiveness of connector coupling device (if applicable)	15f	Rate of load application $\leq 44,5$ N/s			As per manufacturer's specifications
AP 3	Rapid change of temperature	EN 60068 -2-14	-40°C to 70°C Mated or terminated connectors 25 cycles, t = 30 min Recovery time 2 h			
AP 4			Test voltage DC (100 V \pm 15 V), Method A Mated or terminated connectors	Insulation resistance	3a	≥ 500 M Ω
AP 5			All signal contacts and screen / specimens (bulk resistance subtracted)	Contact resistance	2a	≤ 20 m Ω change from initial
AP 6			Contact/contact: Method A Mated or terminated connectors	Voltage proof	4a	DC 1 000 V or AC 1 000 V (peak)
			All contacts to screen: Method A: Mated or terminated connectors			DC 1 500 V or AC 1 000 V (peak)
AP 7			Unmated or unterminated connectors	Visual examination	1a	There shall be no defects that would impair normal operation
AP 8	Cyclic damp heat	EN 60068 -2-38	21 cycles low temperature 25 °C, high temperature 65 °C cold subcycle -10 °C, humidity 93 % Half of the samples in mated or terminated state Half of the samples in unmated or unterminated state			
AP 9			All signal contacts and screen / specimens (bulk resistance subtracted)	Contact resistance	2a	≤ 20 m Ω change from initial
AP 10	Insertion and withdrawal forces (two piece connectors)	13b	Connector locking device depresseded (if applicable)			As per manufacturer's specification
AP 11	Effectiveness of connector coupling device (if applicable)	15f	Rate of load application $\leq 44,5$ N/s			As per manufacturer's specification
AP 12			Unmated or unterminated connectors	Visual examination	1a	There shall be no defects that would impair normal operation

1934

1935

Table D.3 - Test group BP

Test phase	Test			Measurement to be performed		
	Title	EN 60512 Test No.	Severity or condition of test	Title	EN 60512 Test No.	Requirements
BP 1	Locking device mechanical operations (if applicable)		Mechanical operations			As per manufacturer's specification, but equivalent to N = 200 insertions and withdrawals
BP 2	Mechanical operations	9a	N/2 operations Speed 10 mm/s Rest 5 s (two piece connectors). Locking device inoperative			N = 200
BP 3	Flowing mixed gas corrosion	11-7	4 days Half of the samples in mated or terminated state Half of the samples in unmated or unterminated state			Mixture of gases: SO ₂ = (0,5 ± 0,1) 10 ⁻⁶ (V/V) H ₂ S = (0,1 ± 0,02) 10 ⁻⁶ (V/V) Temperature: (25 ± 2) °C Relative humidity: (75 ± 3) %
BP 4			All signal contacts and screen / specimens (bulk resistance subtracted)	Contact resistance	2a	≤ 20 mΩ change from initial
BP 5	Mechanical operations	9a	N/2 operations Speed 10 mm/s. Rest 5 s (two piece connectors). Locking device inoperative			
BP 6			All signal contacts and screen / specimens	Contact resistance	2a	≤ 20 mΩ change from initial
BP 7			DC (100 V ± 15 V) Method A Mated or terminated connectors	Insulation resistance	3a	≥ 500 MΩ
BP 8			Contact/contact: Method A, Mated or terminated connectors	Voltage proof	4a	DC 1 000 V or AC 1 000 V (peak)
			All contacts to screen: Method A, Mated or terminated connectors			DC 1 500 V or AC 1 000 V (peak)
BP 9				Visual examination	1a	There shall be no defects that would impair normal operation

1936

1937

Table D.4 - Test group CP

Test phase	Test			Measurement to be performed		
	Title	EN 60512 Test No.	Severity or condition of test	Title	EN 60512 Test No.	Requirements
CP 1	Vibration	11c	Measurement points as per manufacturer's specification	Contact disturbance	2e	≤ 10 μs
CP 2			Test voltage DC 100 V Method A Mated or terminated connectors	Insulation resistance	3a	≥ 500 MΩ
CP 3			All signal contacts and screen / specimens (bulk resistance subtracted)	Contact resistance	2a	≤ 20 mΩ change from initial
CP 4			Unmated or unterminated connectors	Visual examination	1a	There shall be no defects that would impair normal operation

1938

Table D.5 - Test group DP

Test phase	Test			Measurement to be performed		
	Title	EN 60512 Test No.	Severity or condition of test	Title	EN 60512 Test No.	Requirements
DP 1	Electrical load and temperature	9b	5 connectors 500 h 70°C Recovery period 2 h			0,5 A, 5 connectors No current, 5 connectors
DP 2			Test voltage DC 100 V Method A Mated or terminated connectors	Insulation resistance	3a	≥ 500 MΩ
DP 3			Contact/contact: Method A Mated or terminated connectors	Voltage proof	4a	DC 1 000 V or AC 1 000 V (peak)
			All contacts to screen: Method A Mated or terminated connectors			DC 1 500 V or AC 1 500 V (peak)
DP 4			Unmated or unterminated connectors	Visual examination	1a	There shall be no defects that would impair normal operation
DP 5			All signal contacts and screen / specimens (bulk resistance subtracted)	Contact resistance	1a	≤ 20 mΩ change from initial

1939

1940 **Annex E**
1941 (informative)

1942 **Supported Applications**

1943 **E.1 Supported applications for balanced cabling**

1944 Balanced cabling specified in this European standard is intended to support the applications detailed in this
1945 annex. It is not an exhaustive list and other applications not listed may be supported too.

1946 Balanced cabling applications are correlated to channel performance Classes specified in Clause 5 of this
1947 standard. Generic cabling has been designed to support optical and electrically balanced transmission.
1948 Applications using unbalanced transmission are outside the scope of this standard.

1949 Table E.1 contains established and emerging applications defined by international specifications (e.g.
1950 ISO/IEC standards, ITU Recommendations, IEEE 802 standards and ATM Forum specifications).

1951 Applications supported by generic balanced cabling listed in Table E.1 use the pin assignment recorded in
1952 Table E.2. This mapping relates the modular connector pinning specified by each application standard to the
1953 channel performance classes specified in Clause 5 of this standard.

1954 **E.2 Supported applications for optical fibre cabling**

1955 Optical fibre cabling specified in this European standard is intended to support the applications detailed in this
1956 annex; other applications not listed may also be supported.

1957 Optical fibre cabling applications are correlated to channel performance classes specified in Clause 5 of this
1958 standard. Table E.3 contains established and emerging applications defined by international specifications
1959 (e.g. ISO/IEC standards, ITU Recommendations, IEEE 802 standards and ATM Forum specifications).

1960 Details of application support are provided for each optical fibre category included in Clause 7. For multimode
1961 optical fibre, the optical fibre Classes specified for each application are based upon the greatest channel
1962 length specified in the relevant application standard independent of optical fibre design (i.e. 50/125µm or
1963 62,5/125µm). Table E.4 and Table E.5 contain additional information concerning maximum channel lengths
1964 for 50 µm and 62,5 µm multimode optical fibres and singlemode optical fibres.

1965

Table E.1 - Supported applications using balanced cabling

Application	Specification Reference	Date	Additional Name
Class A (defined up to 100 kHz)			
PBX	National Requirements		
X.21	ITU-T Rec. X.21	1994	
V.11	ITU-T Rec. X.21	1994	
Class B (defined up to 1 MHz)			
S ₀ -Bus (extended)	ITU-T Rec. I.430	1993	ISDN Basic Access (Physical Layer)
S ₀ Point-to-Point	ITU-T Rec. I.430	1993	ISDN Basic Access (Physical Layer)
S ₁ /S ₂	ITU-T Rec. I.431	1993	ISDN Primary Access (Physical Layer)
CSMA/CD 1BASE5	ISO/IEC 8802-3	1996	Star LAN
Class C (defined up to 16 MHz)			
CSMA/CD 10Base-T	ISO/IEC 8802-3	1996	Ethernet
CSMA/CD 100BASE-T4	ISO/IEC 8802-3	1997	Fast Ethernet
CSMA/CD 100BASE-T2	ISO/IEC 8802-3	1997	Fast Ethernet
Token Ring 4 Mbit/s	ISO/IEC 8802-5	1998	
ISLAN	ISO/IEC 8802-9	1996	Integrated Services LAN
ISLAN16-T	ISO/IEC 8802-9 DAM 1	1997	Isochronous Ethernet
Demand Priority	ISO/IEC 8802-12	1998	VGAnyLAN™
ATM LAN 25,60 Mbit/s	ATM Forum af-phy-0040.000	1995	ATM-25/Category 3
ATM LAN 51,84 Mbit/s	ATM Forum af-phy-0018.000	1994	ATM-52/Category 3
ATM LAN 155,52 Mbit/s	ATM Forum af-phy-0047.000	1995	ATM-155/Category 3
Class D (defined up to 100 MHz)			
CSMA/CD 100BASE-TX	ISO/IEC 8802-3	1997	Fast Ethernet
Token Ring 100 Mbit/s	ISO/IEC 8802-5t	1999	High Speed Token Ring
CSMA/CD 1000BASE-T	ISO/IEC 8802-3	1999	Gigabit Ethernet
Token Ring 16 Mbit/s	ISO/IEC 8802-5	1998	
TP-PMD	ISO/IEC FCD 9314-10	2000	Twisted-Pair Physical Medium Dependent
ATM LAN 155,52 Mbit/s	ATM Forum af-phy-0015.000	1994	ATM-155/Category 5
Class E (defined up to 250 MHz)			
ATM LAN 1,2 Gbit/s	ATM Forum af-phy-0162.000	2001	ATM-1200/Category 6
Class F (defined up to 600 MHz)			
FC-100-TP	ISO/IEC 14165-114		

1966

1967

Table E.2 - Modular connector pin assignment for applications

Application	Pins 1 & 2	Pins 3 & 6	Pins 4 & 5	Pins 7 & 8
Supported Applications				
PBX	Class A ^a	Class A ^a	Class A	Class A ^a
X.21		Class A	Class A	
V.11		Class A	Class A	
S ₀ -Bus (extended)	^b	Class B	Class B	^b
S ₀ Point-to-Point	^b	Class B	Class B	^b
S ₁ /S ₂	Class B	^c	Class B	^b
CSMA/CD 1BASE5	Class B	Class B		
CSMA/CD 10BASE-T	Class C	Class C		
CSMA/CD 100BASE-T4	Class C	Class C	Class C	Class C
CSMA/CD 100BASE-T2	Class C	Class C		
Token Ring 4 Mbit/s		Class C	Class C	
ISLAN	Class C	Class C		^b
Demand Priority	Class C	Class C	Class C	Class C
ATM-25,60 Category 3	Class C			Class C
ATM-51,84 Category 3	Class C			Class C
ATM-155,52 Category 3	Class C			Class C
Token Ring 16 Mbit/s		Class D	Class D	
Token Ring 100 Mbit/s		Class D	Class D	
TP-PMD	Class D			Class D
ATM-155,52 Category 5	Class D			Class D
CSMA/CD 100BASE-TX	Class D	Class D		
CSMA/CD 1000BASE-T	Class D	Class D	Class D	Class D
ATM-1200 Category 6	Class E	Class E	Class E	Class E
FC-100-TP	Class F			Class F
^a Option dependent on supplier.				
^b Optional power sources.				
^c Option for continuity of cable screen.				

1968

Table E.3 - Supported applications using optical fibre cabling

Network Application	Maximum channel insertion loss dB			EN 50173 Channel supported on							
	Multimode ^a	Multimode ^a	Singlemode	OM1 optical fibre		OM2 optical fibre		OM3 optical fibre		OS1 optical fibre	
	850 nm	1300 nm	1310 nm	850 nm	1300 nm	850 nm	1300 nm	850 nm	1300 nm	1310 nm	1550 nm
ISO/IEC 8802-3: FOIRL	9,0 (3,3)	-	-	OF-500		OF-500		OF-500			
ISO/IEC 8802-3: 10BASE-FL, FP & FB	12,5 (6,8)	-	-	OF-2000		OF-2000		OF-2000			
ISO/IEC TR 11802-4: 4 & 16 Mbit/s Token Ring	13,0 (8,0)	-	-	OF-2000		OF-2000		OF-2000			
ISO/IEC 8802-12: Demand Priority	7,5 (2,8)	7,0 (2,3)	-	OF-500	OF-2000	OF-500	OF-2000	OF-500	OF-2000		
ATM at 52 Mbit/s ^b	NA	10,0 (5,3)	10,0		OF-2000		OF-2000		OF-2000	OF-2000	
ATM at 155 Mbit/s ^b	7,2	10,0 (5,3)	7,0	OF-500	OF-2000	OF-500	OF-2000	OF-500	OF-2000	OF-2000	
ATM at 622 Mbit/s ^{b,c}	4,0	6,0 (2,0)	7,0	OF-300	OF-500	OF-300	OF-500	OF-300	OF-500	OF-2000	
DIS 14165-111: Fibre Channel (FC-PH) at 133 Mbit/s	NA	6,0			OF-2000		OF-2000		OF-2000		
DIS 14165-111: Fibre Channel (FC-PH) at 266 Mbit/s ^b	12,0	6,0 (5,5)	6,0	OF-2000	OF-2000	OF-2000	OF-2000	OF-2000	OF-2000	OF-2000	
DIS 14165-111: Fibre Channel (FC-PH) at 531 Mbit/s ^b	8,0	-	14,0	OF-500		OF-500		OF-500		OF-2000	
DIS 14165-111: Fibre Channel (FC-PH) at 1062 Mbit/s ^{b,c}	4,0	-	6,0	OF-300		OF-500		OF-500		OF-2000	
ISO/IEC 8802-3: 1000BASE-SX ^c	2,6 (3,56)	-	-	^d		OF-500		OF-500			
ISO/IEC 8802-3: 1000BASE-LX ^{b,c}	-	2,35	4,56		OF-500		OF-500		OF-500	OF-2000	
ISO/IEC 9314-9: FDDI LCF-PMD	-	7,0 (2,0)	-		OF-500		OF-500		OF-500		
ISO/IEC 9314-3: FDDI PMD	-	11,0 (6,0)	-		OF-2000		OF-2000		OF-2000		
ISO/IEC 9314-4: FDDI SMF-PMD ^b	-	-	10,0							OF-2000	
ISO/IEC 8802-3: 100BASE-FX		11,0 (6,0)	-		OF-2000		OF-2000		OF-2000		
IEEE 802.3: 10GBASE-LX4 ^e	2,0	2,0	6,2		OF-300		OF-300		OF-300	OF-2000	
IEEE 802.3: 10GBASE-ER/EW ^{b,e}			10,9								OF-2000
IEEE 802.3: 10GBASE-SR/SW ^e	1,60 (OM1, 62,5 µm) 1,80 (OM2, 50 µm) 2,60 (OM3)							OF-300			
IEEE 802.3: 10GBASE-LR/LW ^{b,e}	-		6,2							OF-2000	

^a The values apply to both 50/125 µm and 62,5/125 µm fibres; where figures differ, the values in parenthesis apply to 50/125 µm fibre.
^b The channel length on singlemode optical fibre may be longer but lies outside the scope of this standard. See the relevant application standard for details.
^c A bandwidth-limited application at the channel lengths shown. The use of lower attenuation components to produce channels exceeding the values shown cannot be recommended.
^d See Table E.4.
^e Application under development

1971 **Table E.4 - Maximum channel lengths supported by optical fibre applications with multimode fibres**

Application	Nominal transmission wavelength nm	Maximum channel length m	
		50 µm fibre ^a	62,5 µm fibre ^b
ISO/IEC 8802-3: FOIRL	850	514	1 000
ISO/IEC 8802-3: 10BASE-FL & FB	850	1 514	2 000
ISO/IEC TR 11802-4: 4 & 16 Mbit/s Token Ring	850	1 857	2 000
ISO/IEC 8802-12: Demand Priority	850	371	500
ATM at 155 Mbit/s ^c	850	1 000	1 000
ATM at 622 Mbit/s ^c	850	300	300
DIS 14165-111: Fibre Channel (FC-PH) at 266 Mbit/s	850	2 000	700
DIS 14165-111: Fibre Channel (FC-PH) at 531 Mbit/s	850	1 000	350
DIS 14165-111: Fibre Channel (FC-PH) at 1 062 Mbit/s ^c	850	500	300
ISO/IEC 8802-3: 1000BASE-SX ^c	850	550	275
ISO/IEC 9314-9: FDDI LCF-PMD	1 300	500	500
EN ISO/IEC 9314-3: FDDI PMD	1 300	2 000	2 000
ISO/IEC 8802-3: 100BASE-FX	1 300	2 000	2 000
IEEE 802.5t: 100 Mbit/s Token Ring	1 300	2 000	2 000
ISO/IEC 8802-12: Demand Priority	1 300	533	2 000
ATM at 52 Mbit/s	1 300	2 000	2 000
ATM at 155 Mbit/s	1 300	2 000	2 000
ATM at 622 Mbit/s	1 300	330	500
DIS 14165-111: Fibre Channel (FC-PH) at 133 Mbit/s	1 300	Not supported	1 500
DIS 14165-111: Fibre Channel (FC-PH) at 266 Mbit/s	1 300	2 000	1 500
ISO/IEC 8802-3: 1000BASE-LX ^c	1 300	550	550

^a Maximum attenuation per km (850 nm / 1 300 nm): 3,5 dB / 1,5 dB;
minimum modal bandwidth (850 nm / 1 300 nm): 500 MHzkm / 500 MHzkm

^b Maximum attenuation per km (850 nm / 1 300 nm): 3,5 dB / 1,5 dB;
minimum modal bandwidth (850 nm / 1 300 nm): 200 MHzkm / 500 MHzkm

^c These applications are bandwidth limited at the channel lengths shown. The use of lower attenuation components to produce channels exceeding the values shown cannot be recommended.

1972 **Table E.5 - Maximum channel lengths supported by optical fibre applications with singlemode fibres**

Application	Nominal transmission wavelength nm	Maximum channel length^{a)} m
ISO/IEC 9314-4: FDDI SMF-PMD	1 310	2 000
ATM at 52 Mbit/s	1 310	2 000
ATM at 155 Mbit/s	1 310	2 000
ATM at 622 Mbit/s	1 310	2 000
DIS 14165-111: Fibre Channel (FC-PH) at 266 Mbit/s	1 310	2 000
DIS 14165-111: Fibre Channel (FC-PH) at 531 Mbit/s	1 310	2 000
DIS 14165-111: Fibre Channel (FC-PH) at 1 062 Mbit/s	1 310	2 000
ISO/IEC 8802-3: 1000BASE-LX	1 310	2 000

^a Maximum attenuation per km (1310 nm / 1 550 nm): 0,5 dB / 1,5 dB

1973

Draft for VOTING

- 1974 **Annex F**
- 1975 (informative)
- 1976 **Electromagnetic characteristics**
- 1977 Cabling consists of passive components and can therefore only be verified for conformance with EN 55022
1978 and EN 55024 together with attached application-specific equipment. However, electromagnetic
1979 characteristics of a network installation are influenced by parameters, which characterise the balance and/or
1980 screening properties of the cabling.
- 1981 Balance is characterised by unbalance attenuation, which is the ratio between the unwanted common mode
1982 signal power, which arises due to imperfections such as asymmetry in the cabling system, and the injected
1983 differential mode signal power. This common mode signal causes radiation and affects immunity. Unbalance
1984 attenuation is characterised for components, including cables and connections. Limits for unbalance
1985 attenuation are also given for cabling. Unbalance attenuation test methods for components are well
1986 established for frequencies up to 100 MHz.
- 1987 Screening effectiveness is characterised for components. At low frequencies up to about 30 MHz transfer
1988 impedance is used for this parameter. Transfer impedance is the quotient of the longitudinal voltage
1989 measured on the secondary side of the screen to the current in the screen, caused by a primary inducing
1990 circuit. This unwanted current causes radiation and affects immunity. At higher frequencies screening
1991 effectiveness is characterised by screening attenuation, which is the ratio between the common mode signal
1992 in the conductors enclosed in the screen and the radiated signal outside the screen.
- 1993 Balance and screening effectiveness properties may be combined in one parameter, coupling attenuation,
1994 which is the ratio between the wanted signal power and the unwanted radiated power from the cabling.
1995 Coupling attenuation is normally measured from 30 MHz to 1 000 MHz.
- 1996 Coupling attenuation can be applied to screened and unscreened elements.
- 1997 Test methods and requirements for components have been developed.
- 1998 Characterisation of coupling attenuation for cabling is for further study. Use of components with good
1999 electromagnetic characteristics, the use of screened or unscreened components throughout a system, and
2000 installation according to manufacturers' instructions, will help to achieve good electromagnetic characteristics
2001 of the cabling.
- 2002 The electromagnetic characteristics of the components referenced in this standard, may be used for
2003 guidance, when application specific electronic equipment is constructed and tested for compliance with
2004 EN 55022 and EN 55024. The relationship between the requirements of the latter EMC standards and these
2005 characteristics is a subject for further study.

2006		Annex G
2007		(informative)
2008		Changes from earlier editions of this European Standard
2009	G.1	General
2010		This European standard contains performance requirements for both components and installed cabling.
2011		These requirements differ from those of the earlier edition of this standard, EN 50173:1995, and those of the
2012		amendment to that edition, EN 50173:1995/A1:2000.
2013		This informative annex contains a historical record of these changes and provides a reference to the
2014		requirements of the earlier editions and amendments of this standard.
2015		The 1 st edition of this standard, EN 50173:1995, contained requirements for:
2016	–	Classes A, B, C and D of installed balanced cabling links;
2017	–	100 Ω (Category 3 and 5) cabling components;
2018	–	120 Ω (Category 3 and 5) cabling components;
2019	–	150 Ω cabling components.
2020		The amendment, EN 50173:1995/A1:2000, contained revisions to the requirements for installed cabling links
2021		and specified the requirements for channels (see G.2) but did not include changes to the component
2022		requirements.
2023		This European standard contains a revision of the requirements for cabling components. For balanced
2024		cabling, Category 3 (100 Ω and 120 Ω) and 150 Ω cabling components have been removed and Category 6
2025		and 7 requirements have been included. For optical fibre cabling, Category OM1, OM2 OM3 and OS1 have
2026		been introduced.
2027		This European standard also contains further modifications to the requirements for installed balanced cabling;
2028		these are described in G.2 and G.3.
2029		References to this European standard should specifically differentiate the relevant requirements and classifications
2030		from those of EN 50173:1995 and EN 50173:1995/A1:2000 by explicitly referencing EN 50173-1:2002.
2031	G.2	Cabling structure
2032		This European standard limits the maximum combined channel (campus backbone, building backbone and
2033		horizontal) length to 2 000 m. This is consistent with:
2034	a)	the scope of the standard;
2035	b)	the intention of delivering optical fibre solution to the desk using OF-2000 channel (see Clause 6);
2036	c)	the maximum supported length of many optical fibre applications.
2037		Figures G.1 and G.2 show the installed cabling performance reference points used in EN 50173:1995 and
2038		EN 50173:1995/A1:2000.

- 2039 EN 50173:1995 specified limits for the link as defined in Figures G.1 and G.2. The link, shown in the figures
 2040 as “Link (1995)” was defined as the channel excluding the cable within the equipment cords.
- 2041 EN 50173:1995/A1:2000 re-defined the reference points as “permanent link” and “channel”. The permanent
 2042 link was defined as the fixed installation including the connecting hardware at each end.

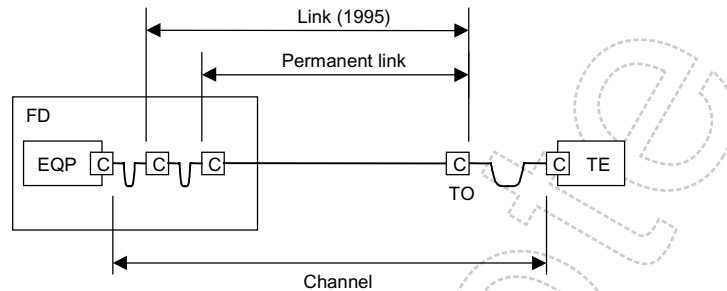

NOTE EN 50173:1995 and EN 50173:1995/A1:2000 did not support the concept of the consolidation point

2043

Figure G.1 - Horizontal cabling model

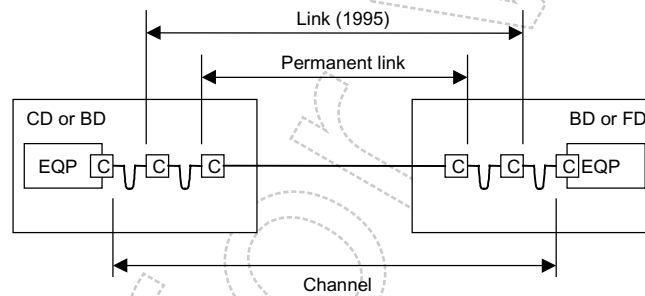

2044

Figure G.2 - Backbone cabling model

- 2045 In all Tables in this annex the abbreviations L, PL and C refer to the performance limits for the Classes of
 2046 “links”, “permanent links” and “channels” respectively.

2047 **G.3 Installed balanced cabling requirements**

- 2048 Tables G.1 to G.7 show the requirements for parameters included in both EN 50173:1995 and
 2049 EN 50173:1995/A1:2000. Component performance requirements for these parameters, included in
 2050 EN 50173:1995, were not changed in EN 50173:1995/A1:2000.

- 2051 Tables G.8 and G.9 show the requirements for parameters included only in EN 50173:1995/A1:2000. The
 2052 component performance requirements for these parameters were not specified in EN 50173:1995/A1:2000.

- 2053 The use of components of EN 50173:1995 does not imply conformance with the requirements of Tables G.8
 2054 and G.9.

2055

Table G.1 - Maximum attenuation

Frequency MHz	Maximum attenuation dB											
	Class A			Class B			Class C			Class D		
	L	PL	C	L	PL	C	L	PL	C	L	PL	C
0,1	16,0	16,0	16,0	5,5	5,5	5,5	N/A	N/A	N/A	N/A	N/A	N/A
1,0	N/A	N/A	N/A	5,8	5,8	5,8	3,7	3,1	4,2	2,5	2,1	2,5
4,0	N/A	N/A	N/A	N/A	N/A	N/A	6,6	5,8	7,3	4,8	4,1	4,5
10,0	N/A	N/A	N/A	N/A	N/A	N/A	10,7	9,6	11,5	7,5	6,1	7,0
16,0	N/A	N/A	N/A	N/A	N/A	N/A	14	12,6	14,9	9,4	7,8	9,2
20,0	N/A	N/A	N/A	N/A	N/A	N/A	N/A	N/A	N/A	10,5	8,7	10,3
31,25	N/A	N/A	N/A	N/A	N/A	N/A	N/A	N/A	N/A	13,1	11,0	12,8
62,5	N/A	N/A	N/A	N/A	N/A	N/A	N/A	N/A	N/A	18,4	16,0	18,5
100,0	N/A	N/A	N/A	N/A	N/A	N/A	N/A	N/A	N/A	23,2	20,6	24,0

NOTE The maximum attenuation for Class D specified in EN 50173:1995 could only be exploited within the limits given by the minima specified for NEXT and ACR.

2056

2057

Table G.2 - Minimum NEXT

Frequency MHz	Minimum NEXT dB											
	Class A			Class B			Class C			Class D		
	L	PL	C	L	PL	C	L	PL	C	L	PL	C
0,1	27,0	27,0	27,0	40,0	40,0	40,0	N/A	N/A	N/A	N/A	N/A	N/A
1,0	N/A	N/A	N/A	25,0	25,0	25,0	39,0	40,1	39,1	54,0	61,2	60,3
4,0	N/A	N/A	N/A	N/A	N/A	N/A	29,0	30,7	29,3	45,0	51,8	50,6
10,0	N/A	N/A	N/A	N/A	N/A	N/A	23,0	24,3	22,7	39,0	45,5	44,0
16,0	N/A	N/A	N/A	N/A	N/A	N/A	19,0	21,0	19,3	36,0	42,3	40,6
20,0	N/A	N/A	N/A	N/A	N/A	N/A	N/A	N/A	N/A	35,0	40,7	39,0
31,25	N/A	N/A	N/A	N/A	N/A	N/A	N/A	N/A	N/A	32,0	37,6	35,7
62,5	N/A	N/A	N/A	N/A	N/A	N/A	N/A	N/A	N/A	27,0	32,7	30,6
100,0	N/A	N/A	N/A	N/A	N/A	N/A	N/A	N/A	N/A	24,0	29,3	27,1

NOTE The minimum NEXT for Class D specified in EN 50173:1995 could only be exploited within the limits given by the maxima specified for attenuation and ACR.

2058

2059

Table G.3 - Minimum ACR

Frequency MHz	Minimum ACR dB											
	Class A			Class B			Class C			Class D		
	L	PL	C	L	PL	C	L	PL	C	L	PL	C
0,1	11,0	11,0	11,0	34,5	34,5	34,5	-	-	-	-	-	-
1,0	N/A	N/A	N/A	19,2	19,2	19,2	35,3	37,0	34,9	-	59,1	57,8
4,0	N/A	N/A	N/A	N/A	N/A	N/A	22,4	24,9	22,0	40,0	47,7	46,1
10,0	N/A	N/A	N/A	N/A	N/A	N/A	12,3	14,7	11,2	35,0	39,4	37,0
16,0	N/A	N/A	N/A	N/A	N/A	N/A	5,0	8,4	4,4	30,0	34,5	31,4
20,0	N/A	N/A	N/A	N/A	N/A	N/A	N/A	N/A	N/A	28,0	32,0	28,7
31,25	N/A	N/A	N/A	N/A	N/A	N/A	N/A	N/A	N/A	23,0	26,6	22,9
62,5	N/A	N/A	N/A	N/A	N/A	N/A	N/A	N/A	N/A	13,0	16,7	12,1
100,0	N/A	N/A	N/A	N/A	N/A	N/A	N/A	N/A	N/A	4,0	8,7	3,1

NOTE The ACR for Class D specified in EN 50173:1995 provided some head room for trade-off between NEXT and attenuation.

2060

2061

Table G.4 - Minimum Return loss

Frequency MHz	Minimum Return loss dB					
	Class C			Class D		
	L	PL	C	L	PL	C
$1 \leq f < 10$	18,0 (ffs)	15,0	15,0	18,0 (ffs)	17,0	17,0
$10 \leq f \leq 16$	15,0 (ffs)	15,0	15,0	15,0 (ffs)	17,0	17,0
$16 \leq f < 20$	N/A	N/A	N/A	15,0 (ffs)	17,0	17,0
$20 \leq f \leq 100$	N/A	N/A	N/A	10,0 (ffs)	$17-7\log(f/20)$	$17-10\log(f/20)$

NOTE The return loss requirements of EN 50173:1995 and EN 50173:1995/A1:2000 demand that the links, permanent links and channels under test be terminated with an impedance equal to that of the design impedance of the cabling (100 Ω, 120 Ω or 150 Ω as applicable). The test methods referred to in EN 50173-1 require that cabling be terminated with an impedance of 100 Ω only.

2062

2063

Table G.5 - Minimum LCL/LCTL

Frequency MHz	Minimum LCL/LCTL dB											
	Class A			Class B			Class C			Class D		
	L	PL	C	L	PL	C	L	PL	C	L	PL	C
0,1	30	-	30	45	-	45	35	-	45	40	-	45
1,0	N/A	-	N/A	20	-	20	30	-	30	40	-	40
4,0	N/A	-	N/A	N/A	-	N/A	ffs	-	ffs	ffs	-	ffs
10,0	N/A	-	N/A	N/A	-	N/A	25	-	25	30	-	30
16,0	N/A	-	N/A	N/A	-	N/A	ffs	-	ffs	ffs	-	ffs
20,0	N/A	-	N/A	N/A	-	N/A	ffs	-	ffs	ffs	-	ffs
100,0	N/A	-	N/A	N/A	-	N/A	N/A	-	N/A	ffs	-	ffs

2064

Table G.6 - Maximum Delay

Frequency MHz	Maximum Delay μs											
	Class A			Class B			Class C			Class D		
	L	PL	C	L	PL	C	L	PL	C	L	PL	C
0,1	20,0 at 0,01 MHz	0,9	20*	5,0 at 1 MHz	-	-	1,0 at 10 MHz	-	-	1,0 at 30 MHz	-	-
1		N/A	N/A		0,9	5*		0,486+ 0,036/ \sqrt{f}	0,544 + 0,036 / \sqrt{f}		0,486+ 0,036/ \sqrt{f}	0,544+ 0,036/ \sqrt{f}
$1 \leq f \leq 16$		N/A	N/A		N/A	N/A		NA	NA			
$1 \leq f \leq 100$		N/A	N/A		N/A	N/A						

* the maximum delay within a horizontal channel = 1,0 μs

2065

2066

Table G.7 - Maximum d.c. loop resistance

Maximum d.c. loop resistance Ω											
Class A			Class B			Class C			Class D		
L	PL	C	L	PL	C	L	PL	C	L	PL	C
560	560	560	170	170	170	40	40	40	40	40	40

2067

2068

Table G.8 – Class D Power sum values

Frequency MHz	PSNEXT dB		PSACR dB		ELFEXT dB		PSELFEXT dB	
	PL	C	PL	C	PL	C	PL	C
1,0	58,2	57,3	56,1	54,8	59,6	57,0	57,0	54,4
4,0	48,8	47,6	44,7	43,1	47,6	45,0	45,0	42,6
10,0	42,5	41,0	36,4	34,0	39,6	37,0	37,0	34,4
16,0	39,3	37,6	31,5	28,4	35,5	32,9	32,9	30,3
20,0	37,7	36,0	29,0	25,7	33,6	31,0	31,0	28,4
31,25	34,6	32,7	23,6	19,9	29,7	27,0	27,1	24,5
62,5	29,7	27,6	13,7	9,1	23,7	21,1	21,1	18,5
100,0	26,3	24,1	5,7	0,1	19,6	17,0	17,0	14,4

2069

2070

Table G.9 - Delay skew

Frequency MHz	Delay skew μs							
	Class A		Class B		Class C		Class D	
	PL	C	PL	C	PL	C	PL	C
$1 \leq f \leq 16$	N/A	N/A	N/A	N/A	0,043	0,050	0,043	0,050
$1 \leq f \leq 100$	N/A	N/A	N/A	N/A	0,043	0,050	0,043	0,050
NOTE Limits for delay skew were not included in EN 50173:1995.								

2071

2072 **Bibliography**

- 2073 EN 55022, *Limits and methods of measurement of radio interference characteristics of information technology equipment (IEC/CISPR 22:1997, modified)*.
- 2074
- 2075 EN 55024, *Information technology equipment - Immunity characteristics - Limits and methods of measurement (IEC/CISPR 24:1997, modified)*.
- 2076
- 2077 EN 60068-1, *Environmental testing - Part 1: General and guidance (IEC 60068-1:1988 + A1:1992)*.
- 2078 EN 61935-1, *Generic specification for the testing of balanced generic cabling in accordance with ISO/IEC 11801 – Part 1: Test methods (IEC 61935-1:2000)*.
- 2079
- 2080 EN ISO/IEC 9314-3, *Information processing systems - Fibre Distributed Data Interface (FDDI) – Part 3: Physical Layer Medium Dependent (PMD) (ISO/IEC 9314-3:1990)*.
- 2081
- 2082 ISO/IEC 8802-3, *Information technology - Telecommunications and information exchange between systems - Local and metropolitan area networks - Specific requirements - Part 3: Carrier sense multiple access with collision detection (CSMA/CD) access method and physical layer specifications*.
- 2083
- 2084
- 2085 ISO/IEC 8802-5, *Information technology – Telecommunications and information exchange between systems - Local and Metropolitan Area Networks - Specific requirements – Part 5: Token ring access method and physical layer specifications*.
- 2086
- 2087
- 2088 ISO/IEC 8802-5 AMD 1, *Information technology - Telecommunications and information exchange between systems - Local and metropolitan area networks - Specific requirements - Part 5: token ring access method and physical layer specifications AMENDMENT 1: Dedicated token ring operation and fibre optic media*.
- 2089
- 2090
- 2091 ISO/IEC 8802-9, *Information technology - Telecommunications and information exchange between systems - Local and metropolitan area networks - Specific requirements - Part 9: Integrated Services (IS) LAN Interface at the Medium Access Control (MAC) and Physical (PHY) Layers*.
- 2092
- 2093
- 2094 ISO/IEC 8802-12, *Information technology - Telecommunications and information exchange between systems - Local and metropolitan area networks - Specific requirements - Part 12: Demand-Priority access method, physical layer and repeater specifications*.
- 2095
- 2096
- 2097 ISO/IEC 9314-4, *Information technology - Fibre distributed data interface (FDDI) - Part 4: Single-mode fibre physical layer medium dependent (SMF-PMD)*.
- 2098
- 2099 ISO/IEC 9314-9, *Information technology - Fibre Distributed Data Interface (FDDI) - Part 9: Low-cost fibre physical layer medium dependent (LCF-PMD)*.
- 2100
- 2101 ISO/IEC 9314-10, *Information technology - Fibre Distributed Data Interface (FDDI) - Part 10: Token ring twisted pair physical layer medium dependent (TP-PMD)*.
- 2102
- 2103 ISO/IEC 14165-111 ⁵⁾, *Information technology – Fibre Channel – Part 111: Physical and Signalling Interface (FC-PH)*.
- 2104

⁵⁾ Approved for publication as International Standard.

- 2105 ISO/IEC 14165-114 ⁶⁾, *Information technology – Fibre Channel – Part 114: 100 MByte/s Twisted Pair*
2106 *Physical Interface (FC-100-TP).*
- 2107 ISO/IEC TR 11802-4, *Information technology - Telecommunications and information exchange between*
2108 *systems - Local and metropolitan area networks - Technical reports and guidelines - Part 4: Token ring*
2109 *access method and physical layer specifications - Fibre optic attachment.*
- 2110 ITU-T Rec. I.430, *Basic user-network interface; Layer 1 specification.*
- 2111 ITU-T Rec. I.431, *Primary rate user-network interface; Layer 1 specification.*
- 2112 ITU-T Rec. X.21, *Interface between data terminal equipment (DTE) and data circuit-terminating equipment*
2113 *(DCE) for synchronous operation on public data networks.*

Draft for Vote

⁶⁾ In preparation by ISO/IEC JTC 1/SC 25.