

Foreword

This European Standard has been prepared by Technical Committee CENELEC TC 215 "Electrotechnical aspects of telecommunication equipment" under the framework of the Mandates M/212 on "Telecommunication cables and cabling systems" and M/239 on "Air traffic management equipment and systems".

The text of the draft was submitted to the formal vote and was approved by CENELEC as EN 50174-2 on 2000-08-01.

The following dates were fixed:

- latest date by which the EN has to be implemented at the national level by publication of an identical national standard or by endorsement (dop) 2001-08-01
- latest date by which the national standards conflicting with the EN have to be withdrawn (dow) 2003-08-01

This standard comprises three parts. All three parts support the specification, implementation and operation of information technology cabling using both balanced copper and optical fibre cabling components. These components may be combined to provide cabling solutions either in accordance with the design requirements of EN 50173 or to meet the requirements of one or more application-specific standards (such as EN 50098-1 or EN 50098-2).

This part, EN 50174-2, contains detailed requirements and guidance relating to the installation planning and practices inside buildings and is intended to be used by the personnel directly involved in the planning and installation of information technology cabling. It shall be used during the different implementation phases when installing information technology cabling, i.e. during the planning phase, the design phase and installation phase.

Annexes designated "informative" are given for information only.
In this standard, annex A is informative.

Contents

Introduction	4
1 Scope	6
2 Normative references	6
3 Definitions and abbreviations	7
3.1 Definitions	7
3.2 Abbreviations	9
4 Safety requirements	10
4.1 Prerequisite	10
4.2 Protection against electric shock	10
4.3 Fire and chemical hazard	11
4.4 Explosive gases	11
4.5 Optical fibre hazard	11
4.6 Separation requirements for metallic cabling	11
5 General installation practices for metallic and optical fibre cabling	11
5.1 General	11
5.2 General precautions	12
5.3 Pre-installation practices	12
5.4 Preparation of cable route	12
5.5 Cabling practices.....	13
5.6 Cable management systems.....	13
5.7 Temporary labelling	14
5.8 Installation of closures.....	14
5.9 Termination practices	14
6 Additional installation practice for metallic cabling	15
6.1 EMC-Considerations	15
6.2 Balanced transmission	15
6.3 Screening.....	15
6.4 Mains power distribution systems	16
6.5 Segregation of circuits.....	19
6.6 Cable containment	22
6.7 Earthing and bonding	25
6.8 Filtering	30
6.9 Protection against very low frequency fields	31
6.10 Electrical isolation components	32
6.11 Surge protective devices	35
6.12 Protection against lightning	36
6.13 Protection against electrostatic discharge (ESD)	36
6.14 Corrosion	37
7 Additional installation practices for optical fibre cabling	38
7.1 General	38
7.2 General precautions	38
7.3 Pre-installation practices	38
7.4 Optical fibre cable practices	38
7.5 Final assembly of closures	38
7.6 Termination practices	38
Annex A (informative) Coupling mechanisms and countermeasures	40
Bibliography	47

Introduction

Within premises, the importance of the information technology cabling infrastructure is similar to that of other fundamental building utilities such as heating, lighting and mains power supplies. As with other utilities, interruptions to service can have serious impact. Poor quality of service due to lack of planning, use of inappropriate components, incorrect installation, poor administration or inadequate support can threaten an organisation's effectiveness.

There are four phases in the successful installation of information technology cabling. These are:

- a) design - the selection of cabling components and their configuration;
- b) specification - the detailed requirement for the cabling, its accommodation and associated building services addressing specific environment(s) identified within the premises together with the quality assurance requirements to be applied;
- c) implementation - the physical installation in accordance with the requirements of the specification;
- d) operation - the management of connectivity and the maintenance of transmission performance during the life of the cabling.

This European standard is in three parts and addresses the specification, implementation and operational aspects. The design issues are covered in EN 50173 and / or other application standards.

EN 50174-1 is intended to be used by personnel during the specification phase of the installation together with those responsible for the quality planning and operation of the installation. It contains requirements and guidance for the specification and quality assurance of the information technology cabling by defining:

- aspects to be addressed during the specification of the cabling;
- quality assurance documentation and procedures;
- requirements for the documentation and administration of cabling;
- recommendations for repair and maintenance.

This part, EN 50174-2, and EN 50174-3 are intended to be used by the personnel directly involved in the implementation phase of the installation. EN 50174-2 is applicable inside buildings and EN 50174-3 is applicable outside buildings.

This part, EN 50174-2, contains detailed requirements and guidance relating to the installation planning and practices by defining:

- 1) planning strategy (road map) and guidance depending on the application, electromagnetic environment, building infrastructure and facilities, etc.
- 2) design and installation rules for metallic and optical fibre cabling depending on the application, electromagnetic environment, building infrastructure and facilities, etc.
- 3) requirements on satisfactory operation of the cabling depending on the application, electromagnetic environment, building infrastructure and facilities, etc.
- 4) the practices and procedures to be adopted to ensure that the cabling is installed in accordance with the specification.

Figure 1 shows the relationships between the standards produced by TC 215 for information technology cabling, namely cabling design standards (EN 50098 series, EN 50173), cabling installation standards (EN 50174 series) and equipotential bonding requirements (EN 50310):

Building design phase	Cabling design phase	Planning phase	Implementation phase	Operation phase
<p>EN 50310</p> <p>5.2: Common bonding network (CBN) within a building</p> <p>6.3: AC distribution system and bonding of the protective conductor (TN-S)</p>	<p>EN 50173</p> <p>or (and)</p> <p>EN 50098-1</p> <p>or (and)</p> <p>EN 50098-2</p> <p>or (and)</p> <p>Other application standards</p>	<p>EN 50174-1</p> <p>4: Specification considerations</p> <p>5: Quality assurance</p> <p>7: Cabling administration</p> <p>and</p> <p>EN 50174-2</p> <p>4: Safety requirements</p> <p>5: General installation practices for metallic and optical fibre cabling</p> <p>6: Additional installation practice for metallic cabling</p> <p>7: Additional installation practice for optical fibre cabling</p> <p>and</p> <p>EN 50174-3</p> <p>and</p> <p>(for equipotential bonding)</p> <p>EN 50310</p> <p>5.2: Common bonding network (CBN) within a building</p> <p>6.3: AC distribution system and bonding of the protective conductor (TN-S)</p>	<p>EN 50174-1</p> <p>6: Documentation</p> <p>7: Cabling administration</p> <p>and</p> <p>EN 50174-2</p> <p>4: Safety requirements</p> <p>5: General installation practices for metallic and optical fibre cabling</p> <p>6: Additional installation practice for metallic cabling</p> <p>7: Additional installation practice for optical fibre cabling</p> <p>and</p> <p>EN 50174-3</p> <p>and</p> <p>(for equipotential bonding)</p> <p>EN 50310</p> <p>5.2: Common bonding network (CBN) within a building</p> <p>6.3: AC distribution system and bonding of the protective conductor (TN-S)</p>	<p>EN 50174-1</p> <p>5: Quality assurance</p> <p>7: Cabling administration</p> <p>8: Repair and maintenance</p>

Figure 1 – Relationship between series EN 50174 and other design standards

1 Scope

This European Standard specifies the basic requirements for the planning, implementation and operation of information technology cabling using balanced copper cabling and optical fibre cabling. This standard is applicable to:

- a) cabling designed to support particular analogue and digital telecommunications services including voice services;
- b) generic cabling systems designed in accordance with EN 50173 and intended to support a wide range of telecommunications services.

This standard is intended for those involved in the procurement, installation and operation of information technology cabling. Furthermore this standard is addressed to:

- architects, building designers and builders;
- main contractors;
- designers, suppliers, installers, maintainers and owners of information technology cabling;
- public network providers and local service providers;
- end users.

This standard is applicable to certain hazardous environments but does not exclude additional requirements which are applicable in particular circumstances, defined by e.g. electricity supply and electrified railways.

This part of the standard:

- c) details the considerations for satisfactory installation and operation of information technology cabling within the environment of a premise building operating a low-voltage electricity distribution system (less than AC 1 000 V rms);
- d) excludes specific requirements applicable to other cabling systems (e.g. power cabling, coaxial cabling); however, it takes account of the effects other cabling systems may have on the installation of information technology cabling (and vice versa) and gives general advice.

2 Normative references

This European Standard incorporates by dated or undated reference, provisions from other publications. These normative references are cited at the appropriate places in the text and the publications are listed hereafter. For dated references, subsequent amendments to or revisions of any of these publications apply to this European Standard only when incorporated in it by amendment or revision. For undated references the latest edition of the publication referred to applies.

EN 50085-1, *Cable trunking systems and cable ducting systems for electrical installations – Part 1: General requirements*.

EN 50085-2-4 ¹⁾, *Cable trunking systems and cable ducting systems for electrical installations – Part 2-4: Service poles*.

EN 50086-1, *Conduit systems for electrical installations – Part 1: General requirements*.

EN 50173, *Information technology – Generic cabling systems*.

EN 50174-1, *Information technology – Cabling installation – Part 1: Specification and quality assurance*.

EN 50174-3 ²⁾, *Information technology – Cabling installation - Part 3: Installation planning and practices outside buildings*.

EN 50288 series, *Multi-element metallic cables used in analogue and digital communication and control*.

EN 50310, *Application of equipotential bonding and earthing in buildings with information technology equipment*.

EN 60439-2, *Low-voltage switchgear and controlgear assemblies – Part 2: Particular requirements for busbar trunking systems (busways) (IEC 60439-2:1987 + A1:1991)*

EN 60825 series, *Safety of laser products (IEC 60825 series)*.

¹⁾ In preparation by TC 213

²⁾ At present committee draft

EN 60950, *Safety of information technology equipment (IEC 60950:1999, modified)*.

EN 61537³⁾ *Cable tray and cable ladder systems for electrical installations (IEC 61537)*.

EN 61558-1, *Safety of power transformers, power supply units and similar – Part 1: General requirements and tests (IEC 61558-1: 1997, modified)*.

HD 384 series, *Electrical installations of buildings (IEC 60364 series)*

HD 384.3 S2, *Electrical installations of buildings - Part 3: Assessment of general characteristics (IEC 60364-3:1993, modified)*.

HD 384.4.41 S2, *Electrical installations of buildings – Part 4: Protection for safety - Chapter 41: Protection against electric shock (IEC 60364-4-41:1992, modified)*.

HD 384.4.42 S1, *Electrical installations of buildings - Part 4: Protection for safety - Chapter 42: Protection against thermal effects (IEC 60364-4-42:1980, modified, + A1:1992 + A2:1994)*.

HD 384.4.43 S1, *Electrical installations of buildings - Part 4: Protection for safety - Chapter 43: Protection against overcurrent (IEC 60364-4-43:1977, modified)*.

HD 384.4.47 S2, *Electrical installations of buildings - Part 4: Protection for safety – Chapter 47: Application of protective matters for safety – Section 470: General – Section 471: Measures of protection against electric shock (IEC 60364-4-47:1981 + A1:1993, modified)*.

HD 384.4.482 S1, *Electrical installations of buildings - Part 4: Protection for safety – Chapter 48: Choice of protective matters as a function of external influences – Section 482: Protection against fire where particular risks or danger exist*.

HD 384.5 series, *Electrical installation of buildings – Part 5: Selection and erection of electrical equipment (IEC 60364-5 series)*.

HD 384.5.52 S1, *Electrical installations of buildings - Part 5: Selection and erection of electrical equipment - Chapter 52: Wiring systems (IEC 60364-5-52:1993, modified)*.

HD 384.5.54 S1, *Electrical installations of buildings - Part 5: Selection and erection of electrical equipment – Chapter 54: Earthing arrangements and protective conductors (IEC 60364-5-54:1980, modified)*.

IEC 61140, *Protection against electric shock – Common aspects for installation and equipment*.

IEC 61312-1, *Protection against lightning electromagnetic impulse - Part 1: General principles*.

3 Definitions and abbreviations

3.1 Definitions

For the purposes of this European standard the following definitions apply.

NOTE The definitions with respect to earthing and bonding are taken from series IEC 60050 and HD 384.2 S1, respectively, and ETS 300 253; reference to these standards is indicated in square brackets.

3.1.1

bonding network (BN)

set of interconnected conductive structures that provides an „electromagnetic shield“ for electronic systems and personnel at frequencies from direct current (DC) to low radio frequency (RF). The term „electromagnetic shield“ denotes any structure used to divert, block or impede the passage of electromagnetic energy. In general, a BN does not need to be connected to earth, but all BNs considered in this standard will have an earth connection

[3.2.2 of ETS 300 253:1995]

³⁾ Approved for circulation as Final Draft

3.1.2

common bonding network (CBN)

principal means for effective bonding and earthing inside a telecommunication building. It is the set of metallic components that are intentionally or incidentally interconnected to form the principal BN in a building. These components include: structural steel or reinforcing rods, metallic plumbing, alternating current (AC) power conduit, protective conductors (PE), cables racks and bonding conductors. The CBN always has a mesh topology and is connected to the earthing network

[3.2.2 of ETS 300 253:1995]

3.1.3

earth electrode

conductive part or group of conductive parts in intimate contact with and providing an electrical connection with earth

[826-04-02 of HD 384.2 S1:1986]

3.1.4

earthing conductor

protective conductor connecting the main earthing terminal or bar to the earth electrode

[826-04-07 of HD 384.2 S1:1986]

3.1.5

earthing network

part of an earthing installation which is restricted to the earth electrodes and their interconnections

[604-04-07 of IEC 60050-604:1989]

3.1.6

electrostatic discharge (ESD)

transfer of electric charge between bodies of different electrostatic potential in proximity or through direct contact

[161-11-22 of IEC 60050-161:1990]

3.1.7

equipotential bonding

electrical connection putting various exposed conductive parts and extraneous conductive parts at a substantially equal potential

[826-04-09 of HD 384.2 S1:1986]

3.1.8

high-voltage

voltage over 1 000 V rms

3.1.9

isolated bonding network (IBN)

bonding network that has a single point of connection ("SPC") to either the common bonding network or another isolated bonding network

NOTE All IBNs considered here will have a connection to earth through the SPC

3.1.10

meshed bonding network (MESH-BN)

bonding network in which all associated equipment frames, racks and cabinets and usually the DC power return conductor, are bonded together as well as at multiple points to the CBN. Consequently, the MESH-BN augments the CBN

[3.2.2 of ETS 300 253:1995]

3.1.11

parallel earthing conductor (PEC)

earthing conductor that is parallel to the cable

3.1.12

PEN conductor

earthed conductor combining the functions of both protective conductor and neutral conductor

[826-04-06 of HD 384.2 S1:1986]

3.1.13

primary protection

primary protection is applied at the location where it can prevent most of the stressful energy from propagating beyond the defined interface

3.1.14

protection

protection is the application of methods and means to prevent the propagation of stressful electrical energy beyond the designed interface. The protection level is normally indicated by a voltage or current rating

[195-06-01 of IEC 60050-195:1998]

3.1.15

protective conductor (PE)

conductor required by some measures for protection against electric shock for electrically connecting any of the following parts:

- exposed conductive parts,
- extraneous conductive parts,
- main earthing terminal,
- earth electrode,
- earthed point of the source or artificial neutral

[826-04-05 of HD 384.2 S1:1986]

3.1.16

resistibility

ability of telecommunication equipment or any network to withstand the effects of certain physical phenomena up to a certain, specified extent and according to a specific criterion

3.1.17

secondary protection

secondary protection is applied subsequent to the primary protection

3.1.18

surge protective device (SPD)

assembly of one or more components intended to limit or divert surges

NOTE The device contains at least one non-linear component

3.2 Abbreviations

AC	alternating current
BN	bonding network
CATV	cabled distribution television
CBN	common bonding network
DC	direct current
EMC	electromagnetic compatibility
EMI	electromagnetic interference
ESD	electrostatic discharge
IBN	isolated bonding network
ISDN	integrated services digital network
ITE	information technology equipment
HV	high-voltage
LV	low-voltage
MESH BN	meshed bonding network
MESH IBN	meshed isolated bonding network
PD	potential difference
PE	protective earthing conductor
PEC	parallel earthing conductor
PEN	conductor combining the functions of both a protective conductor and a neutral conductor.
SPD	surge protective device

4 Safety requirements

4.1 Prerequisite

Provisions shall be taken to ensure that all persons visiting the premises are aware of:

- a) the locations and boundaries of hazardous areas;
- b) the procedures to be adopted when working in or in proximity to these hazardous areas;
- c) fire precautions;
- d) escape routes.

It is assumed that installation of mains power cabling is undertaken in accordance with the requirements of HD 384 and relevant national or local regulations, respectively.

4.2 Protection against electric shock

4.2.1 Active equipment

Only equipment that incorporates safe signal circuitry complying with the SELV circuit and the TNV requirements as defined in EN 60950 shall be connected to information technology cabling.

Equipment connected shall comply with the protection requirements against electric shock of the relevant product safety standards.

The connection of active equipment to information technology cabling shall not introduce safety hazards for other users of the system.

4.2.2 Cabling components

Conductive pathway systems, barriers and fittings shall be included in the protection measures against indirect contact (a means of protection against excessive contact voltage). The means of protection is constituted by, for example, the provision of adequate insulation for the cables and terminals which are used (protective insulation).

The requirements of HD 384.4.41 S2, HD 384.4.47 S2 and HD 384.4.482 S1 and relevant national or local regulations, respectively, shall apply.

Termination points for both information technology cables and mains power cables shall be located and oriented in such a way as to prevent ingress of moisture or other contaminants and to reduce the risk of damage to the cables connected to them. Connecting hardware selected for information technology cabling shall not be interchangeable with the sockets or plugs used for mains power distribution.

Closures and combined terminal and distribution devices (fittings) providing facilities for the termination or (and) distribution of both information technology cables and mains power cables shall be designed to provide separate covers for the two cabling types. Alternatively, a single overall cover is allowed provided that the mains power cabling remains protected to prevent electric shock after removal of the cover. This applies for example to a closure containing separate termination points for telecommunications and mains power cabling, but not for termination points where the network power supply is provided within the information technology cabling termination points itself.

Where both information technology cabling and mains power cabling are contained within a closure then:

- a) if the closure is metallic, it shall be earthed in accordance with the relevant wiring regulations for protective earth;
- b) the compartment in the closure shall have a barrier (either conducting or non-conducting) between the two cable types. If compartment barriers are conductive, they shall be earthed in accordance with the relevant wiring regulations for protective earth;
- c) the front plates on the closure shall allow separate access to the information technology cabling and the mains power cabling and shall be retained such that the use of a tool is necessary to gain access thereby preventing inadvertent misconnection between the mains power and the information technology cabling;
- d) the entry plate for the information technology cables and the mains power cables shall be separate.

4.3 Fire and chemical hazard

The selection of cables shall be based upon the requirements of the relevant European product standards.

NOTE Until these standards are available consultation of national regulations is recommended.

The installation practices shall neither impair the fire behaviour, nor result in the release of dangerous substances of the cabling and associated components.

4.4 Explosive and asphyxiating gases

Lead-acid batteries produce hydrogen and oxygen. If batteries that produce explosive gases are to be installed, provision shall be made for the necessary ventilation and recommended environmental conditions (see HD 384.5.54 S1). National or local regulations shall be complied with.

It is possible for explosive and/or asphyxiating gases to build up in ducts, drawpits, maintenance holes or other closed chambers. Before any worker enters these areas the enclosure shall be well ventilated and the atmosphere shall be tested to detect any potentially hazardous gases.

4.5 Optical fibre hazard

The following practices shall be adopted:

- a) exposed optical fibre ends shall be kept away from the skin and eyes;
- b) the quantity of optical fibre waste shall be minimised;
- c) waste fragments shall be treated with care and collected (not by hand) and disposed of in suitable containers via an approved agency.

The majority of transmission equipment operates using infra-red (non visible) wavelengths. It is difficult to detect such optical signals with the eye or skin directly and it is impossible for the human eye to determine the nature or level of the incident power. Connector end faces, prepared optical fibres or fractured optical fibres shall not be viewed directly unless the power emitted from the optical fibre is known to be safe (as defined within series EN 60825) and under local control.

Closures containing termination points for optical fibre cabling shall be labelled with appropriate warning signs or text.

4.6 Separation requirements for metallic cabling

4.6.1 Metallic information technology cables and mains power cables

Metallic information technology cabling and mains power cabling that share the same cable management system shall be laid according to the requirements specified in 6.5.

Where the requirements of safety and electrical interference demand different limits for either spacing or physical separation, the more stringent requirement shall take precedence.

4.6.2 Cable separation in fire barriers

Where mains power cables (other than single core cables operating at voltages exceeding AC 600 V) pass through a fire barrier it is possible to reduce the physical spacing requirements of 4.6.1 provided that :

- a) the total distance over which the reduction in the separation occurs is not greater than the thickness of the fire segregation barrier plus 0,5 m on either side and
- b) the information technology cables and mains power cables are enclosed in separate metal trunking or conduit and
- c) the requirements for fire barriers are observed and series HD 384.5 is taken into consideration.

5 General installation practices for metallic and optical fibre cabling

5.1 General

Metallic cable management systems and accessories shall be included in the protection measures against electric shock according to 4.2. The method used for the installation of cables into the wall trunking system shall allow for additional cables to be installed in the future without risk of damage.

General EMC requirements and guidance are given in clause 6 and annex A.

Additional installation practices for optical fibre cabling are given in clause 7.

The requirements within this clause do not cover:

- a) any additional requirements for the information technology cables installed in hazardous or stressful environments e. g. electricity supply and electric railway locations. Without any applicable European requirements national requirements will apply;
- b) coaxial cabling and components used within cable distribution systems for television and audio signals, which are covered by the EN 50083 series of standards;
- c) the installation of information technology cabling within buildings operating a mains electricity distribution system at voltages above AC 1 000 V rms.

5.2 General precautions

The delivery of metallic and optical fibre cables shall be monitored to ensure that no mechanical damage occurs during off-loading from vehicles.

Documentation supplied with the cable shall be checked for compliance with the procurement specification and retained.

The cable shall be stored in a suitable place until required. Consideration shall be given to security and environmental conditions.

The cable shall not be unpacked until required.

When pulling-in optical fibre cables, mechanical fuses (or equivalent protection) shall be used to ensure that the maximum tensile loads established by the cable manufacturer are not exceeded. The cable end shall always remain sealed during its installation to prevent the ingress of water and other contaminants.

5.3 Pre-installation practices

The installer shall establish that the routes defined in the installation specification are accessible and available according to the installation programme. The installer shall advise the client of all proposed variations (see 4.8.2 of EN 50174-1:2000).

The installer shall verify that the environmental conditions within the routes and the installation methods to be used are suitable for the design of cable to be installed.

The installer shall identify the proposed locations at which drums (or reels) are to be positioned during the installation programme and should establish the accessibility and availability of those locations.

The installer shall identify proposed locations of cable service loops and should establish their accessibility and availability according to the installation programme.

The installer shall ensure that all necessary installation accessories are available.

The installer shall identify proposed locations of closures and should establish their accessibility and availability according to the installation programme.

The closures shall be located such that it is possible to undertake subsequent measurements, repair, expansion or extension of the installed cabling with minimal disruption and in safety (see 4.6 of EN 50174-1:2000).

The earthing and bonding of all metallic pathway systems shall be undertaken according to the installation specification.

5.4 Preparation of cable route

Where cable is to be installed in shared routes reasonable precautions shall be taken to prevent damage to existing cables or fragile structures within those routes.

Existing catenary wires shall be checked for satisfactory function and, where necessary, catenary wires shall be replaced.

Cable ducts, sub-ducts, tray and trunking shall be installed as required.

All underground ducts should be of a non-porous material and should have smooth internal walls. Sections shall be jointed to prevent ingress of gases, water or foreign materials.

The design of ducts, conduit and trunking should allow installation and removal of the cable without risk of damage.

Cleats or temporary structures (to assist cabling installation) shall be fitted where necessary.

Routes should have draw ropes installed prior to the installation of the cable as required. Under no circumstances should draw ropes be installed concurrently with the cable.

Existing draw ropes should be checked for satisfactory function.

It may be necessary to remove ceiling tiles, floor covers or duct covers. If so, the minimum number shall be removed.

Ducts, fire-ducts and gas seals shall be opened as required.

Any enclosed environments within the routes shall be tested for asphyxiating and explosive gases (see 4.4). Such environments include ducts, maintenance holes (temporary or permanent), cable chambers and any other enclosed, unventilated structures.

Should a gas hazard be detected the installer shall inform the site contact nominated by the client and appropriate action shall be agreed and undertaken.

The installer should ensure that all necessary guards, protective structures and warning signs are used to protect both the cable and all personnel. Relevant national legislation for safe working practices shall be complied with.

5.5 Cabling practices

Proper installation practices shall be observed for cabling to ensure performance of the cabling system over its life cycle. Installation of cable shall be undertaken according to the installation specification.

Performance specifications for cable and connecting hardware assume the use of proper installation practices and cable management techniques according to manufacturers' guidelines. If recommended cable handling practices and installation methods are not observed, it is possible that specified transmission capabilities of cabling components cannot be achieved.

During cable installation, appropriate techniques shall be followed:

- a) the cabling components shall be acclimatised at the recommended environmental condition before installation;
- b) cable management precautions that shall be observed include the elimination of cable stress as caused by tension in suspended cable runs and tightly cinched cable bundles;
- c) minimum bend radii shall never be less than those specified in the product standard;
- d) indoor or outdoor cables shall be used as specified;
- e) cables shall be exposed to neither humidity nor temperature exceeding their specified limits; this includes localised effects such as those from hot air blowers or gas burners;
- f) no forces shall be allowed that cause pressure marks (e.g. through improper fastening or crossovers) on the cable sheath or the cable elements;
- g) joints are only allowed in accordance with the installation specifications;
- h) the maximum pulling tensions of cables taken from the cable specifications shall be observed;
- i) the installation process shall not degrade the intended environmental performance e.g. water seals shall be fitted and fire barriers and load bearing shall conform with the requirements of clause 4;
- j) when installing cables into cable management systems they shall be secured as necessary;
- k) when installing cabling runs in backbone risers, lowering cables rather than pulling them up is recommended (see HD 384.5.52 S2);
- l) in zones where the cables can neither be damaged nor have their transmission properties adversely affected, cables may run in the open (rising zones, connecting ducts, PABX rooms, etc.).

5.6 Cable management systems

Cable management systems shall comply with European standards:

- Conduit systems to EN 50086-1 and the relevant part 2;
- Trunking and ducting systems to EN 50085-1 and the relevant part 2;
- Busbar trunking systems to EN 60439-2;
- Tray and ladder systems to EN 61537;

- Services poles to EN 50085-2-4.

5.7 Temporary labelling

When pulling several runs along a route at the same time, the loose ends of each cabling run shall be labelled with a unique identifier. For final labelling see EN 50174-1.

Where appropriate, warning signs and labels shall be fitted in accordance with the installation specification.

5.8 Installation of closures

Closures shall be located as defined in 4.6 of EN 50174-1:2000.

Closures should be fixed or mounted in position using the recommended fittings. Patch panel closures should be fixed to prevent the ingress of foreign material into unprotected adaptors. All adaptors should be fitted with suitable protective caps.

Closures should be labelled and identified according to the installation specification.

Any electrical equipment provided within closures should be installed according to the relevant national standards.

Documentation should be collated which provides the information necessary to allow subsequent installation of the cable into the closures.

The cable entrance shall:

- a) maintain the environmental performance of the closure;
- b) provide the necessary cable support and prevent kinking at the point of entry into the closure;
- c) provide strain relief for the cable if not already done by separate fixtures within the closure;
- d) provide suitable glands to allow the entry of optical fibre cables.

Any cabling not contained within a management system should be protected from physical damage by use of appropriate sleeving.

According to the relevant standard, each cable element should be uniquely identifiable using one or more of the following methods:

- 1) colour coding;
- 2) labelling;
- 3) physical position routing.

Following jointing or termination, the cable elements should be arranged within the closure in a manner that allows access to individual connectors, joints and elements with minimal disruption to neighbouring components during subsequent repair, expansion or extension of the installed cabling.

Where closures are configured as patch panels:

- adaptors should be inspected for contamination;
- terminated cables shall be connected into the adaptors in accordance with the connectivity defined within the installation specification.

Final acceptance testing (see EN 50346) should be undertaken following final assembly of the closure into the desired location.

5.9 Termination practices

Manufacturers' installation instructions for the connector and cable shall be strictly followed. If special tools are required for termination, then only those recommended by the manufacturer shall be used.

The connecting hardware used for copper cabling shall be installed to provide minimal signal impairment by preserving wire pair twists as closely as possible to the point of mechanical termination (by not changing the original twist), see EN 50173. In addition only a minimum of the cable jacket shall be removed.

6 Additional installation practice for metallic cabling

6.1 EMC-Considerations

Electromagnetic Compatibility (EMC) of an installation implies that the emission from an installed system remains below accepted limits as defined in the relevant standard and that the installed system exhibits the specified immunity in a specific electromagnetic environment.

The guidelines in this clause shall be taken into account. Manufacturers' instructions that may require more stringent installation practices, shall also be followed.

Safety always takes precedence over EMC and protection.

Several international and European documents define different electromagnetic environments which influence the installation practice. A direct way to take account of these different environments is to consider the relevant disturbing sources found. Annex A contains an EMC checklist and guidance on actions to take.

6.2 Balanced transmission

6.2.1 General

Balanced transmission lines minimize induced noise on the signal lines.

6.2.2 Design guidelines

The performance of a balanced transmission line depends on symmetry along the length of the line. This applies to the components of the link, to the external environment of the transmission line and to the signal on the transmission line. If symmetry cannot be achieved alternative countermeasures should be chosen.

To reduce emissions from and to improve immunity of a transmission line the balance of the transmission line should be considered over the full frequency spectrum of the application. To increase the immunity the balance should also be considered for frequencies out of the band of the intended signals.

Screening the cable or using metallic or composite cable management systems specially designed for EMC purposes reduce the asymmetric interaction between the environment and the conductors of a pair.

The signal put on the transmission line should be as symmetric as possible otherwise it will radiate. This requires a good common mode rejection ratio of the output port. Common mode noise could be induced on a balanced transmission line. To minimize this noise disturbing the transmission system the receiver requires a high common mode rejection ratio.

If all the above requirements cannot be achieved isolation transformers or filters should be inserted at the ports. This may not be possible when an application requires to pass signals with a DC content through the ports.

If the input signal is not symmetric a balance to unbalance transformer (balun) should be inserted at the ports to reduce emission. This may not be possible when an application requires to pass DC signals through the ports.

6.2.3 Installation guidelines

The transmission line should be installed such that the symmetry of the components of the link is not compromised. For this reason sharp bending of cables should be avoided.

6.3 Screening

6.3.1 General

A cable screen creates a separation between the external electromagnetic environment and the transmission line inside the screen. The performance of the screen depends on the screening effectiveness of the components and on the way the components are connected to each other and to a local earth.

For further information see IEC/TR 61000-5-2.

6.3.2 Installation guidelines

If a screened cabling system is to be installed the following should be considered:

- a) screen not bonded to equipment: not recommended;
- b) screen bonded at both ends to equipment (i.e. connected with the chassis of the terminal equipment): reduces electro-magnetic radiation by the principle of the Faraday cage;
- c) screen earthed on one end: provides protection against electrical fields;
- d) screen earthed on both ends: provides protection against electrical fields and, where problems with high screen currents exist, partially compensates the interfering magnetic field;
- e) screen in all cases a) to d): virtually no effect against very low frequency magnetic fields (e.g. 50 Hz), unless special materials are used (μ -metal, Permalloy, etc.).

According to the above considerations:

- 1) the cable screen shall be continuous from the transmitter to the receiver. In any case a cable screen shall be connected at both ends to terminals or sockets;
- 2) the cable screen shall have a low transfer impedance according to EN 50173;
- 3) special attention shall be paid to the assembly of connection elements. The screen contact should be applied over 360 degrees according to the principle of a Faraday cage. The screening connection should be of a low impedance design (see Figure 2);
- 4) the cable screen should totally surround the cable along its entire length. A screening contact applied only through the drain wire has little effect at high frequencies;
- 5) the screening should continue through an adequate screen connection; normal pin contacts shall not be used;
- 6) avoid (even small) discontinuities in the screening: e.g. holes in the screen, pigtails, loops; discontinuity dimensions of the order of 1 % to 5 % of the wavelength can decrease the overall effectiveness of screening.

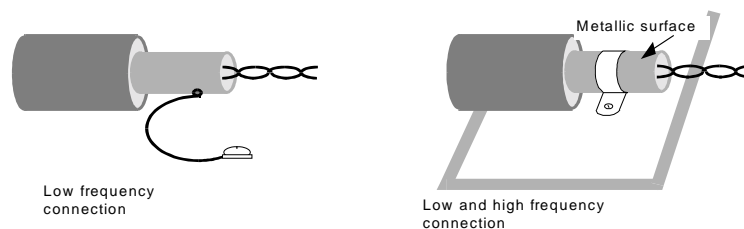

NOTE When a screen or earth conductor exists outside the cable construction it is regarded as a PEC, which should be earthed at both ends. Inner screens or earth leads are also earthed at one or both ends. For TN-C or TN-C-S systems see A.6.2.2.

Figure 2 - Connection of the cable to the local earth

6.4 Electricity distribution systems

6.4.1 General

Public electricity supplies in various countries are often made available in different voltages and phase arrangements to premises. Preferred arrangements and logical choices within premises often depend upon the size of the installation load, its supporting equipment, upon existing internal distribution system and the public mains supply delivered. When the electricity distribution system within an existing building is unsatisfactory or obsolescent it is often better to install dedicated power cabling to be used only by telecommunication equipment at the most favourable voltage to ensure minimum interaction with other building functions.

6.4.2 Design guidelines for earthing

In all cases, the electrical installation shall be provided with a main equipotential bonding (according to HD 384.4.41 S2, HD 384.5.54 S1 and EN 50310) which connects:

- a) the main earthing terminal;
- b) any installed earth electrode or earth electrode network;

- c) metallic water pipes and other extraneous conductive parts (e.g. metallic construction elements of the building);
- d) the (main) protective earthing conductors.

All other bondings including the examples listed below should be electrically connected to the main equipotential bonding network to form a mesh network:

- down conductors of lightning protection systems of the building;
- functional earthing conductors (see IEC 60364-5-548);
- interconnecting earthing conductors (e.g. from a nearby building);
- parallel earthing conductors (see series IEC/TR 61000-5).

6.4.3 Earthing of the AC distribution system

The different electricity distribution systems (TN-S, TN-C-S, TN-C, TT and IT system) are described in HD 384.3 S2. However, a PEN conductor through which unbalanced currents as well as the accumulation of harmonic currents and other disturbances are transmitted shall not be considered as appropriate earthing. In addition TT and IT distribution systems shall have more corrective measures, particularly against over-voltage. Therefore:

- a) there should be no PEN within the building, i.e. the respective option in 546.2.1 of HD 384.5.54 S1:1988 should not be used;
- b) wherever possible, the TN-S system should be used (see EN 50310). Exceptions exist due to existing high-voltage electricity distribution systems, which are TT or IT, or where a high continuity of supply is required by the application (hospitals) or by national regulations.

NOTE A PEN conductor within the building can be considered on the path from the building entrance to the first termination point where it will have to be split into a separate neutral conductor (N) and protective earthing conductor (PE).

6.4.4 Installation guidelines

6.4.4.1 Non linear load consideration

Non linear loads (fluorescent lamps, switch mode power supply devices, etc.) generate harmonic currents on the supply network and these may overload the neutral conductor. In such situations, it may be necessary to:

- a) oversize the HV/LV or LV/LV transformers to provide a low impedance source;
- b) segregate the applications using star power distribution for the different applications by means of different feeders or transformers (lighting, motors, ITE, etc.), see Figure 3;
- c) use adequate cross section for the neutral conductor, at least identical to the phase conductor, to cope with unbalanced loads and triple harmonics;
- d) equalise the loads (sharing) between phases.

In case of a power supply arrangement according to Figure 3c) providing measures for interconnection of different feeders, electromagnetic interference with respect to sensitive equipment should be considered. In a situation where two feeders are interconnected, care should be taken that only one central earthing terminal or electrode is used for both transformers.

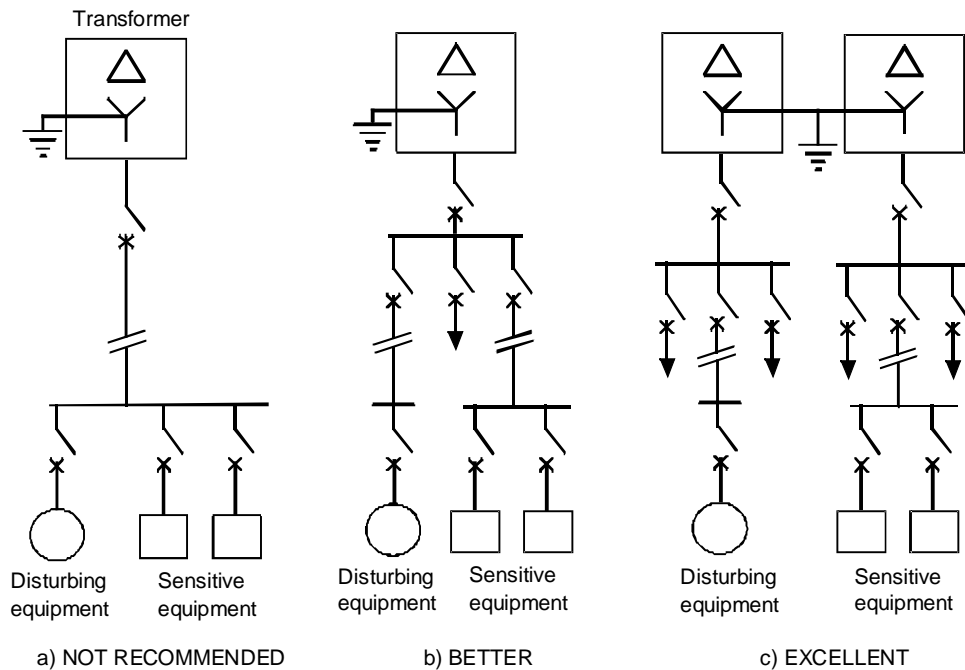

Figure 3 - Segregation of the electricity distribution for different applications

6.4.4.2 Electricity distribution systems influence

Planners and designers of the electrical installation shall consider the following points to prevent the electricity distribution system possibly influencing sensitive equipment:

- potential sources of interference, e.g. power substations, power transformers, lifts, high electrical currents in busbars shall be located away from sensitive equipment;
- metal pipes (e.g. for water, gas, heating) and cables should enter the building at the same place;
- metal sheets, screens, metal pipes and connections of these parts shall be bonded and connected to the main equipotential bonding of the building with low impedance conductors;
- the choice of a common route for power and signal cable with an adequate separation (by distance or screening) to avoid large inductive loops formed by different power cabling systems;
- it is recommended to use either one single multi-conductor cable for all power supply purposes or – in cases of higher power levels – current carrying bar systems with low-level magnetic fields.

6.4.4.3 TN-S system consideration

If the TN-S system has been chosen, the short duration and transient overvoltage described in respectively HD 384.4.42 S1 and HD 384.4.43 S1, are reduced to a minimum. However, the following phenomena need consideration in certain cases:

- installation of surge protective devices close to the origin of the electrical installation according to the exposure of the electricity distribution system and the resistibility of equipment (further details are given in HD 384.4.43 S1);
- influence of short circuit currents which create short duration overvoltages up to 1,45 times the nominal voltage and voltage differences along the PE and other earthing conductors shall be taken into account during the general design of the installation;
- a long duration overvoltage up to 250 V.

6.4.4.4 TT or IT systems

If the electricity distribution system is of TT or IT type, or if the IT system is required by regulations or for continuity of service, care shall be taken that:

- sensitive equipment withstands short duration overvoltages (up to AC 1 200 V in TT system according to HD 384.4.43 S1), or transformers are installed preferably at the origin to use the TN-S system;

- b) surge protective devices are installed according to HD 384.4.43 S1 or better using a risk assessment method, in particular when using overhead lines for the supply distribution;
- c) in IT systems, equipment shall withstand the phase to phase voltage between each phase and accessible conductive parts. In general, equipment insulated are appropriate, but electronic equipment shall comply to the requirements of EN 60950 related to IT system or similar requirements, or be supplied through transformers.

If the TN-C section cannot be changed into a TN-S section for the distribution within the building, conductive paths forming loops between the different TN-S sections shall be avoided.

6.4.4.5 Power cabling and screening

Adequate separation (distance or screening) between power and information technology cables shall be provided. Power and information technology cables shall cross over at right angles.

Power cabling systems with single core conductors should be enclosed in bonded metallic enclosures or equivalent (see 6.5.1).

6.4.4.6 Measures for signal connections in existing installations

In existing buildings which include a PEN conductor, or where there is EMI on information technology cables due to inadequate provisions in the electrical installation (see 548.5 of IEC 60364-5-548:1996), one of the following methods shall be considered to avoid or minimise the problem.

- a) use of optical fibre links for signal connections;
- b) use of electrical class II equipment (EN 60950);
- c) use of local transformers with separate windings (double-wound transformers) for the supply of the information technology equipment, taking into account 312.2.3 of HD 384.3 S2:1995 and 413.1.5 of HD 384.4.41 S2:1996 for IT systems (local IT systems), or 413.5 of HD 384.4.41 S2:1996, for protection by electrical separation (e.g. transformers according to EN 61558-1).

6.5 Segregation of circuits

6.5.1 General

Information technology cables and power supply cables which share the same cable management systems, building voids or similar shall be laid according to the requirements of this subclause.

Testing of secure/safe/sufficient separation according to IEC 61140 (for frequencies of 50 Hz to 60 Hz) shall be taken into consideration. Safety and EMI, in some cases, require different clearances. Safety always has highest priority.

Electrically conductive cable management systems, fittings, and barriers shall be protected against indirect contact (a means of protection against excessive contact voltage), see HD 384.4.41 S2.

6.5.2 Design guidelines

The minimum separation between power cables and information technology cables to avoid disturbances is related to many factors such as:

- a) the immunity level of equipment connected to the information technology cabling system to different electromagnetic disturbances (transients, lightning pulses, bursts, ring wave, continuous waves, etc.);
- b) the fitting of the equipment to the earthing system;
- c) the local electromagnetic environment (simultaneous appearance of disturbances, e.g. harmonics plus bursts plus continuous wave);
- d) the electromagnetic spectrum;
- e) the distances that the cables run in parallel (coupling zone);
- f) the type of cable;
- g) the coupling attenuation of the cables;
- h) the quality of the attachment between the connectors and the cable;
- i) the type and the fitting of the cable management system.

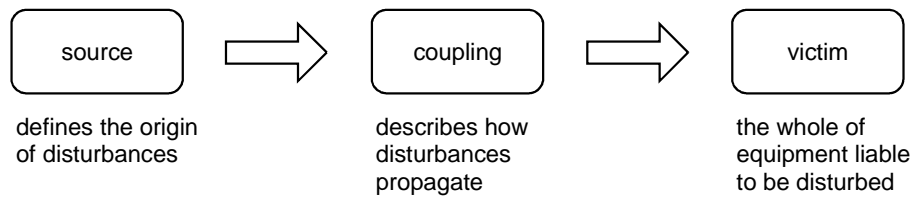

Figure 4 - Schematic representation of an EMC problem

For the purpose of this standard it is assumed that the electromagnetic environment complies with series EN 50081 and series EN 50082 for conducted and radiated disturbances (power lines). Moreover it is assumed that the information technology cabling supports any existing application covered by EN 50173:1995 and EN 50173:1995/A1:2000.

For horizontal cabling the following applies (see Figure 5):

- if the horizontal cabling length is less than 35 m no separation is required in case of screened cabling;
- for length greater than 35 m the separation distances apply to the full length excluding the final 15 m attached to the outlet.

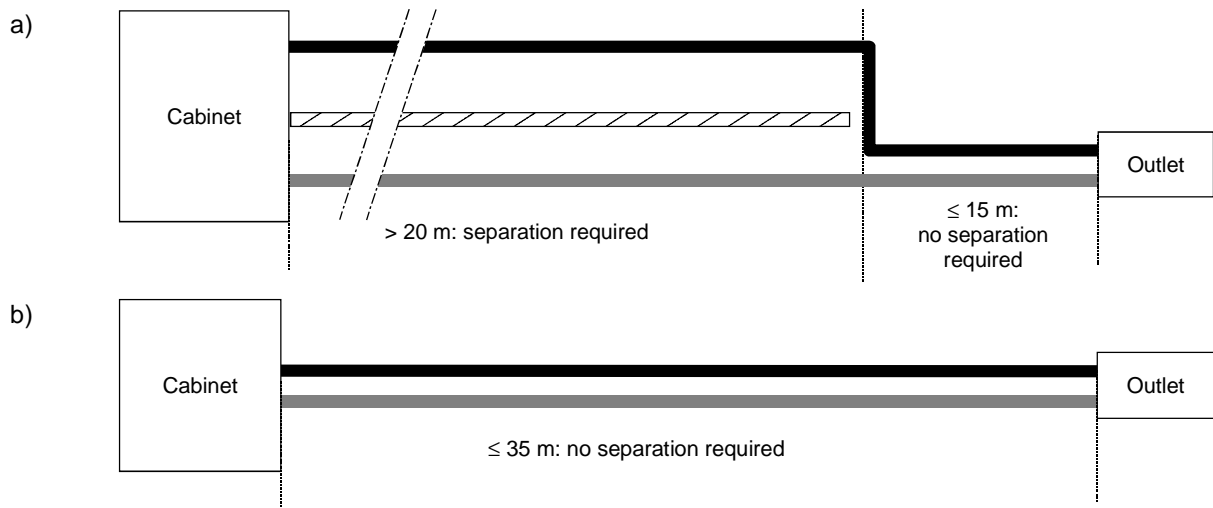

Figure 5 - Separation between power and data cables

When cabling is installed in an electromagnetic environment with emission and immunity requirements exceeding the levels defined in series EN 50081 and series EN 50082, the separation distances given in Table 1 are implemented on an end to end basis. Depending on the actual electromagnetic environment, the distances may need to be increased.

For the backbone the separation distances given in Table 1 shall apply end to end.

Table 1 - Information technology cable separation from power cabling

Type of installation	Distance A		
	Without divider or non-metallic divider ¹⁾	Aluminium divider	Steel divider
Unscreened power cable and unscreened IT cable	200 mm	100 mm	50 mm
Unscreened power cable and screened IT Cable ²⁾	50 mm	20 mm	5 mm
Screened power cable and unscreened IT cable	30 mm	10 mm	2 mm
Screened power cable and screened IT cable ²⁾	0 mm	0 mm	0 mm
1) It is assumed that in case of metallic divider, the design of the cable management system will achieve a screening attenuation related to the material used for the divider. 2) The screened IT cables shall comply with EN 50288 series.			

Figures 6 and 7 illustrate these requirements for both parallel cable runs without (Figure 6) and with (Figure 7) dividers:

- 1) the minimum distance A in Figure 6a) is the worst situation between fixing points;
- 2) where neither fixing is provided nor other physical restraints such as a divider system are present, a separation A of 0 mm shall be assumed (Figure 6b));
- 3) for cables installed in adjacent compartments of a cable management system or another pathway that incorporates a divider, the minimum separation between cables shall be assumed to be equal to the thickness of the divider A, unless cable fixing is provided (Figure 7a));
- 4) for cables installed in non-adjacent compartments of a cable management system or another pathway that incorporates more than one divider, the minimum separation between cables shall be assumed to be equal to the distance A between the dividers, unless cable fixing is provided (Figure 7b)).

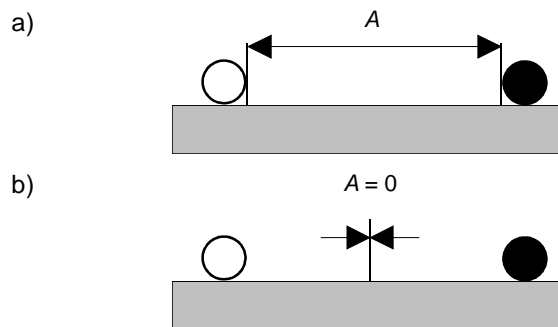

Figure 6 - Examples of power cables and information technology cables that run parallel without divider

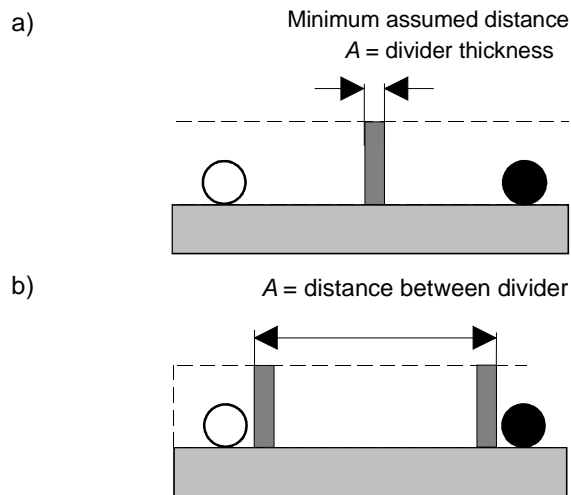
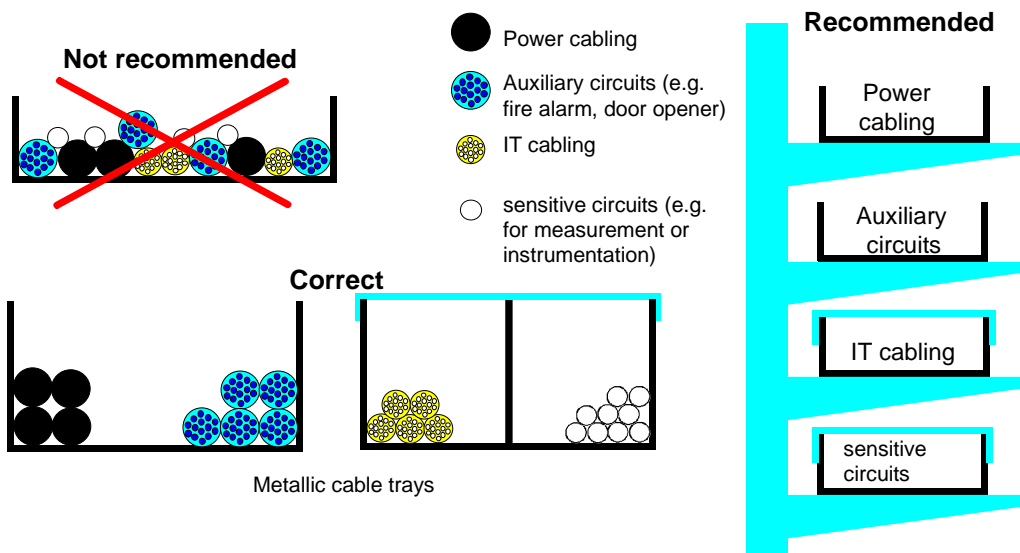

Figure 7 - Examples of power cables and information technology cables that run parallel with a divider

6.5.3 Installation guidelines

The minimum distance between information technology cables and fluorescent, neon, and mercury vapour (or other high-intensity discharge) lamps shall be 130 mm. Electrical wiring closets and data wiring closets should ideally be in separate cabinets. Data wiring racks and electrical equipment should always be separated.

Cable crossing shall be at right angles. Cables for different purposes (e.g. mains power and information technology cables) should not be in the same bundle. Different bundles should be separated electromagnetically from each other, see Figure 8.



NOTE All metallic parts are electrically well bonded

Figure 8 - Separation of cables in cable management systems

6.6 Cable containment

6.6.1 General

Cable management systems are available in metallic and non-metallic forms. Some metallic materials offer improved resistance to EMI. The cable management system, if conductive, shall provide a continuous, well

conducting metallic structure over its full length to ensure that it takes effect as a parallel earthing conductor (PEC).

6.6.2 Design guidelines

The choice of material and the shape depend on the following considerations:

- a) the strength of the electromagnetic fields along the pathway (proximity of electromagnetic conducted and radiated disturbing sources);
- b) the authorized level of conducted and radiated emissions;
- c) the type of cabling (screened, twisted, optical fibre);
- d) the immunity of the equipment connected to the information technology cabling system;
- e) the other environment constraints (chemical, mechanical, climatic, fire, etc.);
- f) any future information technology cabling system extension.

Non-metallic cable management systems are suitable in the following cases:

- electromagnetic environment with permanently low levels of disturbance;
- the cabling system has a low emission level;
- optical fibre cabling.

For metallic system components, the shape (plane, U-shape, tube, etc.), rather than the cross section will determine the characteristic impedance of the cable management system. Enclosed shapes are best (by reducing the Common Mode coupling). Trays often have slots for easy attachment of cable. The least harmful of these is with a small slot parallel to the axis of the tray. Slots perpendicular to the tray axis should not be used.

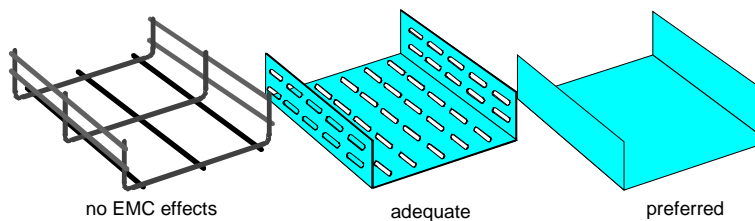

Figure 9 - EMC ranking for different metallic trays

Usable space within the cable tray should allow for an agreed quantity of additional cables to be installed. The bundle height into the cable tray shall be lower than the side walls as shown in Figure 10. The use of overlapping lids improve the cable tray EMC performances.

For a U shape, the magnetic field decreases near the two corners. For this reason, deep sections are preferred (see Figure 10).

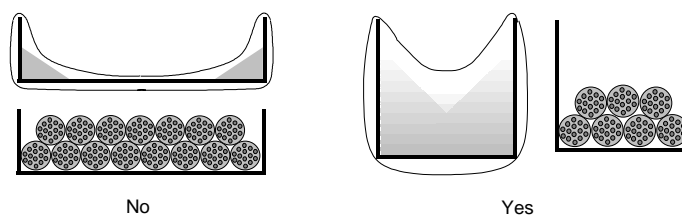

Figure 10 - Cable arrangement in a metallic section

6.6.3 Installation guidelines

6.6.3.1 Metallic or composite cable management systems specially designed for EMC purposes

When a metallic or composite cable management system specially designed for EMC purposes is constructed with several shorter elements, care should be taken to ensure the continuity by correct bonding between different parts. Preferentially, the parts are welded over their full perimeter. Riveted, bolted or screwed joints are allowed, provided that the surfaces in contact are good conductors (no paint or insulating

coat), that they are safeguarded against corrosion and that a good electrical contact between the two parts is ensured.

The shape of the metallic section should be maintained over its full length. All interconnections shall have a low impedance. A short single lead connection between two parts of the cable management system will result in a high local impedance and, therefore, degrades its EMC performance (see Figure 11).

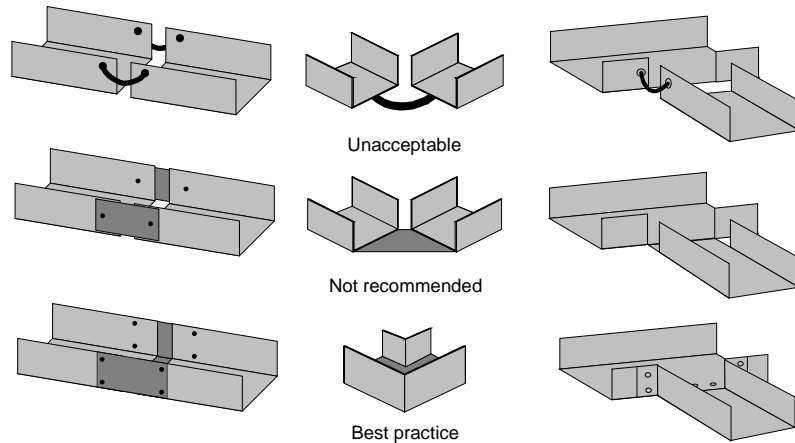

Figure 11 - Continuity of metallic system components

From frequencies of a few MHz upwards, a 10 cm mesh strap between the two parts of the cable management system will degrade the shielding effect by more than the factor of 10.

Whenever adjustments or extensions are carried out, it is vital that close supervision is undertaken to ensure that this is done according to the EMC recommendations (e.g. not replacing a metallic conduit by a plastic one).

Metallic construction elements of buildings can serve EMC objectives very well. Steel beams of L-, H-, U-, or T-shape often form a continuous earthed structure, that offers large cross-sections and large surfaces with many intermediate connections to earth. Cables are preferentially laid against such beams. Inside corners are preferred to outside surfaces (see Figure 12).

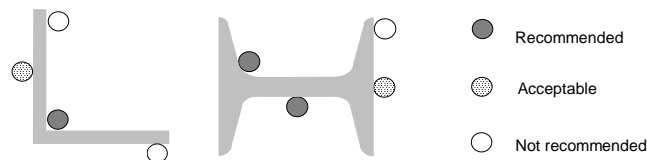

Figure 12 - Location of cables inside metallic construction elements

Metallic or composite cable management systems specially designed for EMC purposes should always be connected to the local earth at both ends. For long distances (more than 50 m) additional connections to the earthing system at irregular intervals are recommended. All the earthing connections should be as short as possible.

Covers for metallic cable trays shall meet the same requirements as the cable trays. A cover with many contacts over the full length is preferred. If that is not possible, the covers should be connected to the cable tray at least at both ends by short connections less than 10 cm (e.g. braided or mesh straps).

When a metallic or composite cable management system specially designed for EMC purposes is to be interrupted for crossing a wall (e.g. fire barriers), the two metallic sections shall be bonded with low impedance connections (see Figure 13).

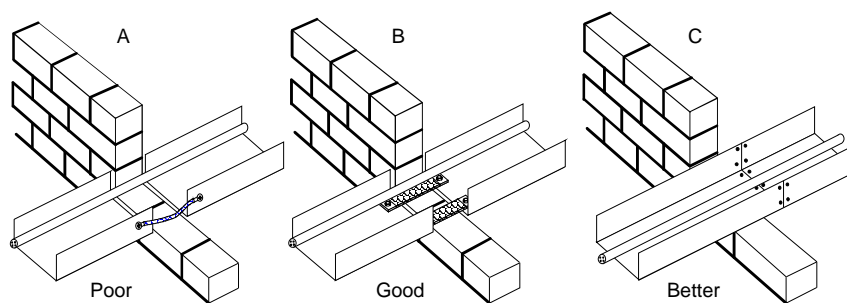

Figure 13 - Interruption of metallic sections

6.6.3.2 Non-metallic cable management systems

Where the apparatus connected to the cabling system by unscreened cables are not affected by low frequency disturbances, to improve EMC performance of non-metallic cable management systems, a single lead, as a parallel earth conductor, connected to the local earthing system at both ends should be added inside the cable management system. The connections should be made on a low impedance metallic part (e.g. a large metal wall of the apparatus cabinet).

The parallel earth conductor should be designed to withstand large common mode and power fault currents.

6.7 Earthing and bonding

6.7.1 General

The basic purposes of earthing and bonding are applicable to both unscreened and screened cabling systems:

- safety: touch voltage limitation and earth fault return path;
- EMC: zero potential reference and voltage equalisation, screening effect.

Stray currents inevitably propagate in an earthing network. It is impossible to remove all sources of disturbances at a site. Ground loops are also inevitable. When an external magnetic field affects the site, a field produced by lightning for example, potential differences are induced in the loops and currents flow in the earthing system. So the earthing network inside a building depends largely on the countermeasures taken outside the building.

As long as the currents flow in the earthing system and not in the electronic circuits, they do not have any harmful effects. However, when the earth networks are not equipotential, when they are connected to the earth terminal in a star connection for example, high frequency stray currents will flow everywhere, i.e. also on signal cables. Equipment can suffer disturbance and can even be destroyed.

The specifications of EN 50310 are intended to provide optimum earthing and bonding conditions for buildings, where information technology installations are to be operated. EN 50310 shall be applied at least in the case of newly constructed buildings and whenever possible in existing buildings (e.g. on the occasion of refurbishment).

The installation management in a campus shall collaborate with all parties (e.g. power, Telecom, ITE, railways, tramways, CATV, etc.).

6.7.2 Design guidelines

For best results the earthing system should be bonded in three dimensions, in particular for multi-storey buildings having a networked data system. It should be remembered that one of the greatest dangers is the induction of the surge magnetic field in the ground loops. The surge field is essentially horizontal and induces the worst stray voltages in vertical loops.

Two consecutive floors should be bonded by all the conducting links which go through the flooring. These interconnections are made either by conductors which already exist (cable ducts, piping, etc.) or by large section additional conductors. The preferred mesh size for a vertical bond is about 3 m to 4 m, particularly in areas with a high concentration of electronic equipment.

In practice, any conductor can contribute to the equipotential characteristics of the earthing system: earthing conductors, metal tubing, conduits, cable ducts, metal framework, deck plates, lintels, gratings, beams, metal structures, door frames, etc. This type of bonding often improves the electromagnetic properties of systems considerably and contributes to the safety of personnel.

The type of conductor has little effect on equipotential characteristics. A steel conductor of the same cross-section and length as a copper conductor will have a different resistance but the same high frequency impedance.

Each item of equipment is connected to the earth terminal by its own protective earth conductor (PE), see Figure 14.

Where the equipment is interconnected, and if the protective earth conductors are long, or the items of equipment are some distance from each other, the results are a high common impedance between equipment, large ground loops, and a poor equipotential state particularly at high frequencies, see Figure 15.

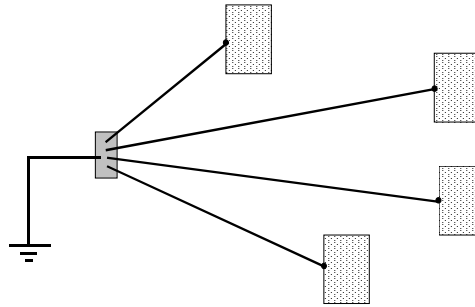

Figure 14 - IBN (star network)

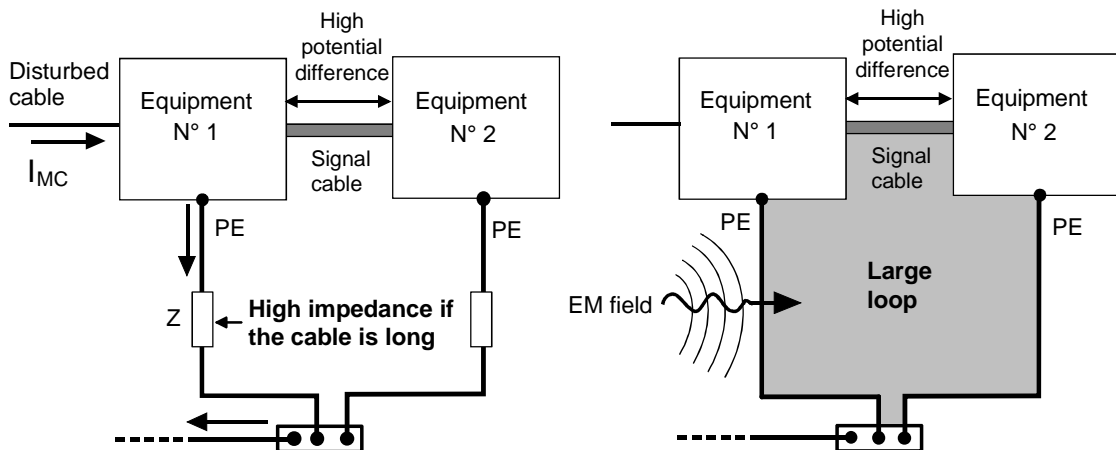

Figure 15 - Example of high common impedance and large loop

This configuration makes electronic equipment more vulnerable to electromagnetic disturbances.

Adding an additional bonding conductor between items of equipment improves this situation, see Figure 16.

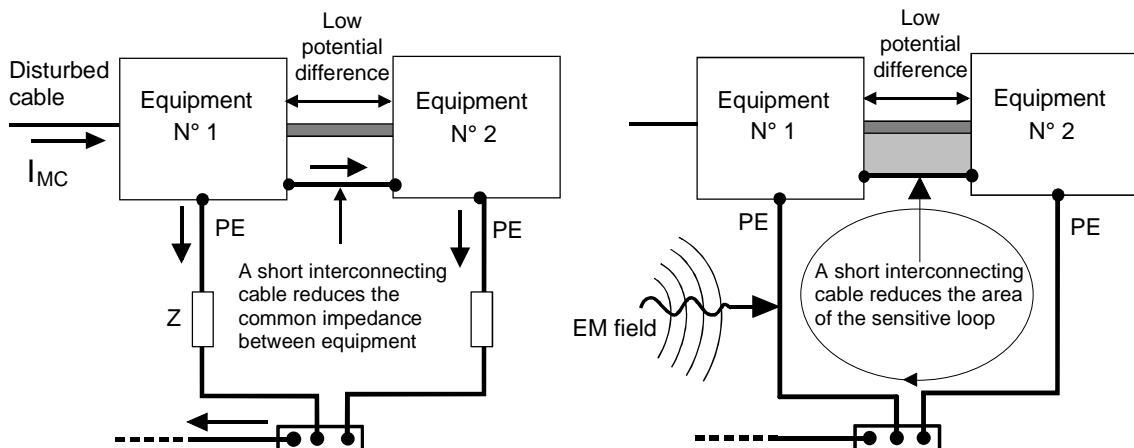

Figure 16 - Example of low common impedance and small loop

The new arrangement for the star earthing network improvement is shown in Figure 17.

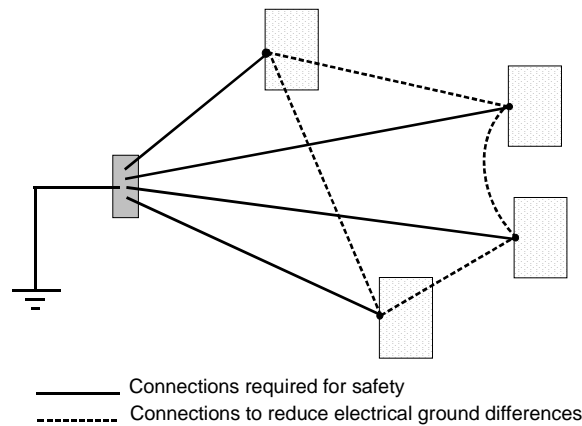

Figure 17 - Improvement of star earthing network

6.7.3 Installation guidelines

6.7.3.1 Bonding networks

Although the ideal bonding network is a plate or a fine mesh grid, experience shows that for most electrical disturbances a mesh of about 3 m per square is sufficient. This forms a mesh bonding network. Examples of different bonding networks are shown in Figure 18. The minimum structure comprises a conductor (e.g. copper strip or cable) surrounding the room as shown in the Figure regarding the CBN example.

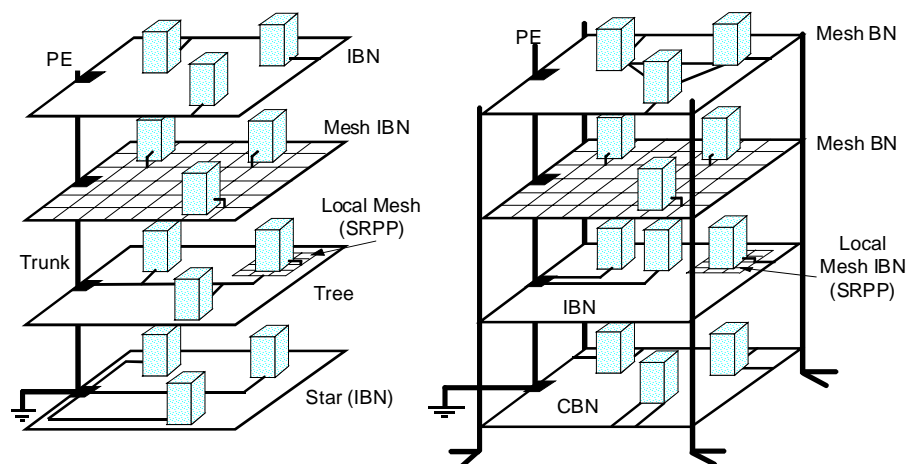

Figure 18 - Examples of bonding networks

The length of the connection between a structural item and the bonding network should not be more than 50 cm, and an additional connection should be added in parallel at another point some distance away. Connecting the earthing bus of the electrical switchboard of an equipment block to the bonding network (see below) should be made with an inductance of less than about 1 μH (0,5 μH , if possible). For example it is possible to use a single 0,5 m conductor, or two parallel 1 m conductors (not too close to each other - at least 0,5 m - to minimise the mutual inductance between the two conductors).

An attempt should be made to connect to the bonding network at a junction point (see Figure 19) in order to divide the high frequency currents without making the connection physically longer. The section of the bonding straps is not important although flat section is preferred; the strap should be as short as possible.

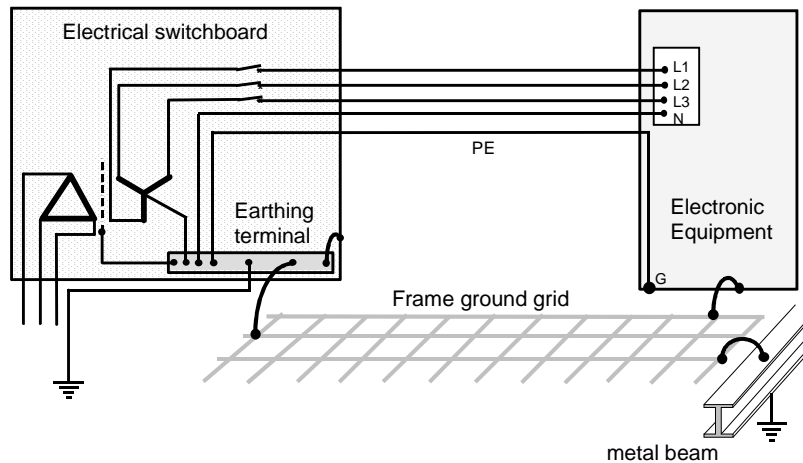

Figure 19 - Mesh BN example

It is easier and safer to bond all equipment frame grounds as a matter of routine (see Figure 19) without worrying too much about which cables are carrying signals, rather than attempting only to connect equipment frame grounds which happen to be exchanging signals the day when the cabling work is performed.

6.7.3.2 Parallel earthing conductor (PEC)

The purpose of a parallel earthing conductor is to reduce the common mode current through leads that carry differential mode signals by reducing common impedance and loop areas.

The parallel earthing conductor shall be designed to withstand large currents when it is used as lightning protection, or as power fault current return. When a cable screen acts as a parallel earthing conductor, it is not designed to cope with these large currents. The first approach is to route the cable through metallic construction elements, or conduits, which then act as another parallel earthing conductor for the total cable. An additional possibility is to route the screened cable closely with a large cross-section parallel earthing conductor, the cable screen and parallel earthing conductor being connected at both ends to the local earth of the equipment or apparatus.

For very long distances, additional connections of the parallel earthing conductor to the earthing system should be implemented at irregular intervals between the apparatus. These extra connections provide an early return path for the disturbance current through the parallel earthing conductor. For U-shaped conduits, shields and tubes, the additional earth connections should be made at the outside, preserving the separation from the inside ("shielding" effect).

6.7.3.3 Bonding straps

For bonding straps, suitable conductors include metal strips, metal mesh straps or round cables. For high frequency systems, metal strips or braided straps are better (skin effect). A round conductor has, at high frequencies, a higher impedance than a flat conductor with the same material cross section. The length/width ratio $\leq 5:1$ should be kept as far as possible (see Figure 20).

Wide and short bonding straps are also suitable. As long as the length of the additional links remains below about 0,5 m, it is useful to include them up to high frequencies of about 30 MHz. It is also relevant to connect the frame grounds of adjacent cabinets that are not exchanging signals, although this is less important.

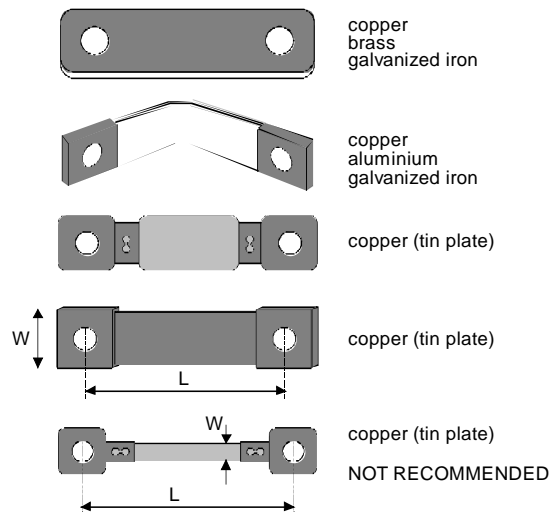

Figure 20 - Example of bonding straps

6.7.3.4 Connecting techniques

Welding or soldering are the best solutions to ensure a very low impedance connection between two parts of a conduit, with a good stability with time. Welding or soldering material should be close to the basic metal.

Spot welding, riveting, screwing or bolting are suitable to provide the necessary contact pressure to obtain reliable and durable connections. Nevertheless, these methods require the contact of clean metal surfaces (paint and other non-conducting protective coatings should be removed from the contact areas) and due precautions to avoid corrosion. This arrangement requires periodic maintenance in industrial installations environment.

6.7.3.5 Raised floors

The shielding effect of a raised floor is directly tied to its equipotential. If there is no contact between the flooring slabs (slabs with anti-static rubber seals), or if the contact through support brackets is not guaranteed (pollution, corrosion, moisture, etc., or no bracket at all), it is necessary to add a frame ground grid. In this case, all that is required is to provide good electrical connections between the metal uprights. Small spring-operated clamps can be used for hooking up the uprights to the frame ground. The ideal solution is to bond each of the uprights, but it is often sufficient to only bond one in two or even three in each direction (see Figure 21). A grid size of 1,5 m to 2 m per bond is suitable in most cases. The copper section should be 10 mm^2 or greater.

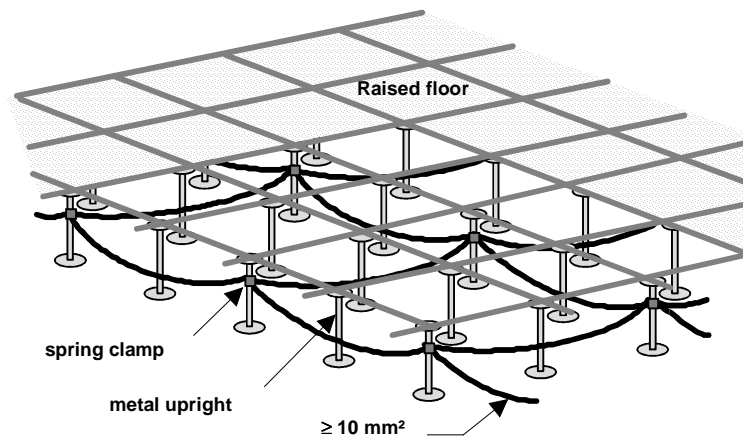

Figure 21 - Raised floor

6.7.3.6 Transient Suppression Plate

The transient suppression plate is used as a potential reference on which all EMI components are bonded (filters, voltage suppressors, screens of screened cables, etc.) as shown in Figure 22. It reduces noise currents which could otherwise be coupled into underfloor information technology cables from subfloor reinforcing steel. For example, a metal plate of 1 m x 1 m or more, provides bypass to the reinforcing steel in the concrete of the subfloor under the raised floor.

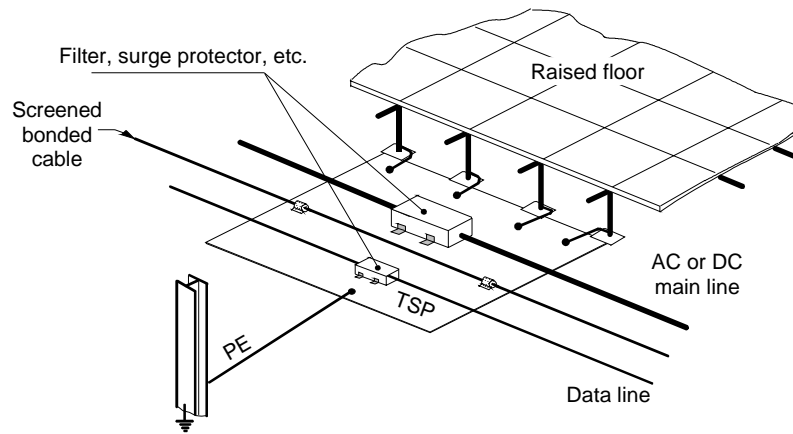

Figure 22 - Example of transient suppressing plate installation details

6.8 Filtering

6.8.1 General

Filters are used in power systems and in information technology systems where, despite normal application of the general guidelines of installation and mitigating methods, disturbance levels exceed the immunity level of the installed equipment. Filters are usually inserted into a circuit so that all intended circuit energy passes through them. They should therefore perform their function without impairing normal circuit operation.

Filters can have a two-fold effect by protecting the environment from disturbances generated within equipment and also protect the equipment against disturbances generated externally to the equipment concerned.

Each installation will be different and an individual study is necessary.

6.8.2 Design guidelines

As a general rule, filters should be located as near as possible to the apparatus which is the source or victim, to minimise the impedance of the connection. Filters are either enclosed in the apparatus enclosure, or mounted in a dedicated unit installed in its proximity for example use of a transient suppression plate.

When surge protective devices are used, they often need to be located before filters.

6.8.3 Installation guidelines

6.8.3.1 General

Physical separation of input and output lines is facilitated by the feed-through mounting technique of the filters. Other mounting techniques can require proper screening of cables to assure their electromagnetic separation. Inputs and outputs of filters should be arranged as far apart as possible; leads from the input and output side should never be in the same bundle. Filtered leads should never encounter the unfiltered ones to minimize coupling effects.

If screened conductors are to be connected to the filter case, EMI gland type connections should be used. The mounting of a filter is often more important than type of filter. Poor mounting of an otherwise good filter will produce poor filtering. The filter earth connection impedance should be as low as possible to avoid the generation of disturbances that would otherwise be applied in common mode to the apparatus to be protected. See Figure 23 for an example.

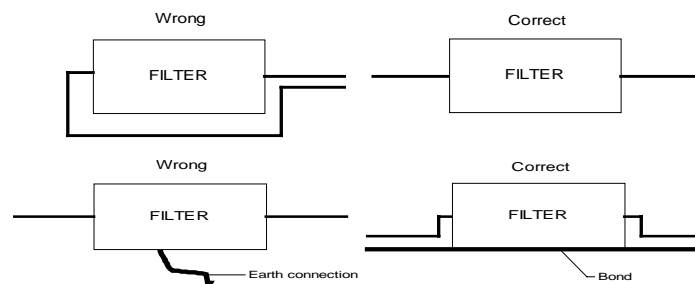

Figure 23 - Earthing and bonding of filters

When a filter is installed in a metallic cable management system, all the cables shall be filtered, otherwise the coupling between the cables could impair the efficiency of the filters (see Figure 24). In this case it would be better to filter all the cables or use a transient plate.

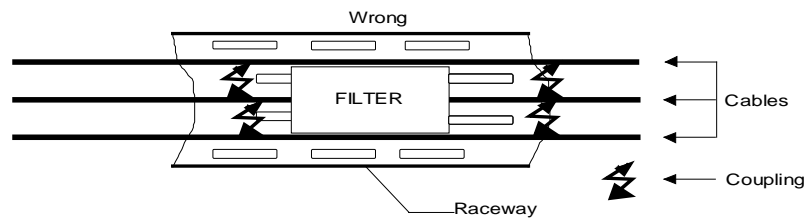

Figure 24 - Mounting of filters

6.8.3.2 Power cabling

The use of filters shall not interrupt the PE connecting the equipment.

When the filter is located outside the equipment it is preferable that the wires from the filter should be twisted and positioned close to the equipotential structure.

When the installation is protected by a residual current device ensure that the leakage current of the filter is lower than the rated residual current of the residual current device (see Figure 25).

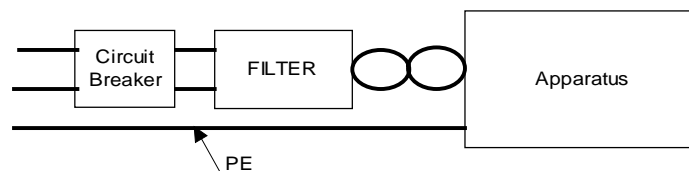

Figure 25 - Installation of power filter

6.8.3.3 Information technology cabling

The following parameters are important and shall be maintained to obtain a good filtering to protect the cabling:

- screening integrity;
- low mismatch impedance;
- balance.

6.9 Protection against very low frequency fields

6.9.1 General

Electricity supply installations such as

- high and medium voltage lines and transformers,
- high-voltage distribution bus bar systems,
- electric traction installations

create low frequency (electric and magnetic) fields which can disturb information technology equipment and installations.

6.9.2 Design guidelines

Very low frequency fields can be diverted with the aid of:

- a) high permeability metals;
- b) loop constructions compensating magnetic fields;

c) metallic walls or parts thereof, made of copper or aluminium of sufficient thickness.

Provided that the segregation distances are met cases and countermeasures against very low frequency fields are:

EXAMPLE 1) Power cabling produces too high magnetic field in relation to the environment in question;

Countermeasure: Use a screened power cable or put an overall screen around the power cable, made of high permeability metal. Care shall be taken to consider saturation and mechanical shocks.

EXAMPLE 2) a magnetic field arises, because part of the global (mains) current flows back through the earth and not through the cabling (see Figure 26);

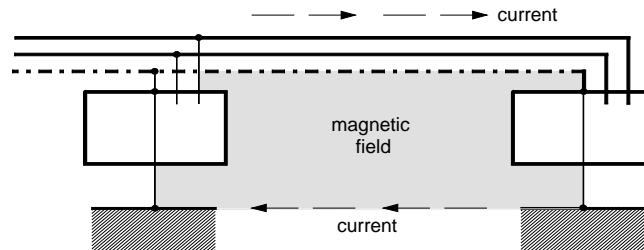

Figure 26 - Magnetic field

Countermeasure: in case this magnetic field produces disturbances, this situation can be difficult. To overcome it, a short circuit loop made of high conductive metal (such as copper) could compensate in a good part this field and thus overcome the disturbing situation.). Other countermeasures could be taken e.g. at the "sink" side. See EXAMPLE 1). The last possibility is to change the installation in such a way that no magnetic fields are created.

6.9.3 Installation guidelines

Some local codes impose other restrictions and requirements and will in most cases take precedence over other guidelines.

Avoid loops as explained in annex A and shown in Figure 26. Install instead as shown in Figure 27.

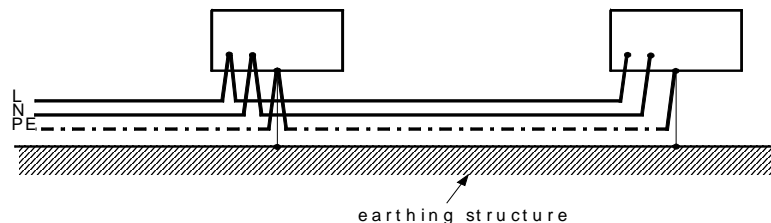

Figure 27 - Earthing arrangement

Arrange the high-voltage distribution bus bar system in such a way as to minimize the emission of magnetic fields.

Avoid installing information technology equipment near to disturbing sources.

6.10 Electrical isolation components

6.10.1 General

The installation of an electrical isolation component (isolation transformer or optocouplers) are primarily used for the prevention of common mode signals on installed cabling or to interrupt the possible loop formed by the power and information technology cables.

Optocouplers (including optical fibres) can be used to reduce EMI because they ensure a galvanic separation that avoids conducted disturbances and they do not radiate.

6.10.2 Design guidelines

The choice of the correct electrical information technology isolation component is application dependent.

Furthermore the designer and/or installer should consider:

- screened/unscreened cabling;
- mechanical compliance;
- disconnectivity;
- active/passive component;
- the protection level needed against common mode disturbances;
- the allowable asymmetrical disturbance at the information technology port to be protected;
- the unbalanced attenuation required;
- the compliance to EMI and safety standards if applicable;
- the insulation needs. e.g. breakdown voltage.

The choice of the correct electrical power isolation component depends upon the following:

- screened/un-screened cabling;
- mechanical compliance;
- disconnectivity;
- active/passive component;
- change of the AC power distribution system into a TN-S system if applicable;
- an equipment will have to be changed from safety protection class I into class II (see EN 60950) if applicable. There is no fixed earth connection or touch current problem which forbids the mentioned change;
- the protection needed against common mode disturbances (opening of loops);
- the allowable asymmetrical disturbance at the entrance interface (port) of the device to be protected;
- the power to be transferred;
- the compliance to EMI and Safety standards if applicable;
- stray capacitance.

6.10.3 Installation guidelines

The installation guidelines for electrical isolation components for the protection of information technology cabling from electrical surges developed by a rise of earth potential are covered within EN 50174-3.

Buildings installed with an equipotential earthing system may need to install isolation transformers between the telecommunications cable pairs end-points (terminations) and connecting equipment which have a direct or indirect connection to the equipotential network, to prevent earth loops (see Figures 28 and 29). The isolation transformer effectively supplies a 'barrier' against an end-to-end current flow (Common Mode). The isolation transformer will attenuate low frequency AC currents and the amount (effectiveness) will depend upon its technical characteristics.

6.11 Surge protective devices

6.11.1 General

Voltage and current transients (surges) occur on power and information technology cabling. The origins of these surges can be local or remote, and can be destructive to equipment and be a safety hazard to personnel.

This subclause deals only with the application of surge arresters (surge protective devices) in the cabling part (power and information technology cabling) of the whole installation. The adequate protection of equipment does not form part of this subclause, although some equipment influences the protection measures in the cabling part.

Surge arrestors when installed within a telecommunication system will add additional impairments (resistance, capacitive and/or inductance). These additional impairments shall be taken into consideration when designing the telecommunication network.

6.11.2 Design guidelines

The choice of the surge protective devices depends on the following considerations:

- a) the lightning protection zones - if any - of the site;
- b) the amount of energy (voltage, current, duration) to be diverted;
- c) the location of surge protective devices (primary or secondary protection);
- d) the allowable amount of disturbance (voltage, current, duration) at the interface (port) of the device;
- e) protection against differential or common mode or both;
- f) the type of the transmitted signal or cabling service e.g. EN 50173;
- g) the leakage current or stray capacitance values;
- h) operational parameters e.g. response time, latching voltage;
- i) the compliance to product, EMI and safety standards where applicable.

Practical protection units which are commonly supplied and installed to protect cabling entering a building are also given within EN 50174-3.

6.11.3 Installation guidelines

Suppliers' installation instructions shall be complied with.

Where surge protective devices are used to reduce high voltages appearing in information technology cabling due to induction from power line, they should be fitted to all pairs and should be located as close as possible to the main earth terminal of the building (see EN 50174-3).

The surge protective devices fitted at the main distribution frame and all subscriber terminals reduce the risk of damage to lines but their main function is to protect components having lower dielectric strength than the cables. See Recommendations ITU-T K.20, K.21, K.44 and K.45.

Protection against fire and explosion could be provided by enclosing the surge protective devices in a suitable enclosure. Surge protective devices should not be mounted in rooms where fire or explosion risk exists unless special precautions are taken.

Connections of information technology cabling and earthing systems to surge protective devices should be as short as possible to minimize surge voltage levels between the lines and the equipotential bond point (see Figure 30).

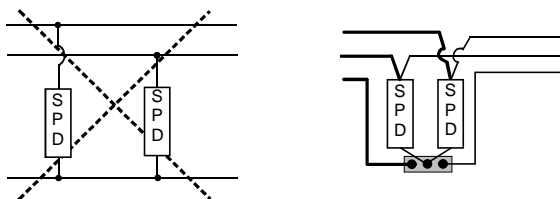

Figure 30 – Short connections of surge protective devices

6.12 Protection against lightning

6.12.1 General

A direct lightning strike can cause an enormous amount of physical damage. However, the indirect effects from a nearby strike can also cause damage by inducing voltage surges onto mains and information technology cables.

The probability of damage for both direct and indirect effects is discussed in IEC/TR 61662. It takes into account several parameters such as the annual ground flash density, the area of influence of the structure and the existence of a lightning protection system.

6.12.2 Design guidelines

A guide for the selection of protective measures is given in IEC/TR 61662.

This selection is closely linked to the comparison between the risk of damage and the acceptable risk which depends upon the surge probability and the electromagnetic susceptibility of the equipment.

This guide should be considered together with ENV 61024-1 to select the protection level of the lightning protection system. Once this level is chosen, the protection against lightning electromagnetic impulse shall be achieved according to IEC 61312-1.

6.12.3 Installation guidelines

For the installation of the protection network local rules and codes of practices apply.

Planners and designers should also consider the guidelines contained within HD 384.4.442 S1.

To reduce effects of induced lightning, decrease the area of any loop e.g. use of screened cables.

6.13 Protection against electrostatic discharge (ESD)

6.13.1 General

Main characteristics of ESD threat are:

- a) charge up voltage level: normally between 2 kV and 6 kV and in exceptional circumstances up to 40 kV;
- b) discharge current level: up to 50 A with a rise time of nanoseconds.

There is a risk of potential danger for ESD disturbances in the following situations:

- c) Raised floors which are charged due to air circulation (for climatic reasons) within a multi storey building;
- d) ESD charged objects or persons, for example due to exposure to the sun, approaching near to uncharged equipment.

NOTE The guidelines laid down in R044-001 contain further advice.

6.13.2 Design guidelines

The most common source of danger from static electricity is the retention of charge on a conductor or on insulating sheath where virtually all the stored energy can be released in a single spark to earth or to another conductor. The accepted method of avoiding the hazard is to connect all conductors and sheaths to each other and to earth by electrical paths with resistances sufficiently low to permit the relaxation of the charges.

Antistatic or conductive type materials can be used to avoid the retention of static electricity. The most appropriate maximum value for the resistance to earth from all parts of such equipment is 1 M Ω although values up to 100 M Ω are acceptable in some cases.

6.13.3 Installation rules

Connect all partially conductive and non-metallic cable management systems to each other and to earth by electrical paths to permit the relaxation of any electrostatic charges (10 Ω).

Antistatic or conductive type flooring materials used should be earthed to avoid the retention of static electricity (10 Ω).

6.14 Corrosion

When interconnecting metal conductors, electro-chemical compatible metals should be used to minimise corrosion effects, otherwise this could deteriorate the connecting initial impedance. When surfaces of metals with different electro-chemical properties are connected together there will be a galvanic potential between these surfaces. The rate of corrosion depends on this electro-chemical potential between two metals and the conditions under which contact is made. In practice it has been found that a maximum of 300 mV is ideal for maintaining a low galvanic effect in a moderately corrosive environment. To ensure a low impedance contact and a reliable electrical contact, lower potential differences shall be taken into account (100 mV to 500 mV). Humidity and environmental factors of the location shall be taken into consideration, too.

Values in the shaded zone (see Table 2) indicate compatible metal couples; however, this should not be construed as being devoid of galvanic action. Compatible couples represent a low galvanic effect.

To minimise dissimilar metal corrosion, the following preventive measures shall be used:

- select metals which form a compatible couple (e.g. use nickel, not naval brass, in contact with silver);
- interpose a metal which reduces the potential difference between the two metals (e.g. tin plate brass to be used next to aluminium or use a tin or cadmium plated washer between a steel screw in contact with aluminium);
- design the metal contact such that the relative area of the cathodic (more noble) metal is smaller than the anodic metal one (e.g. stainless steel screws in aluminium chassis);
- apply corrosion inhibitor such as zinc chromate primer or paste (e.g. use zinc chromate inhibitor when assembling steel screws in aluminium).

Table 2 - Galvanic couples (in mV) for some common metals (electrolyte: water + 2% NaCl)

	Platinum	Stainless steel	Silver	Nickel or Monel	Copper	Brass	Tin	Lead	Soft steel	Aluminium 99.5%	Hard steel	Cadmium	Chromium	Zinc
Platinum	0	250	350	430	570	650	800	840	1 000	1 090	1 095	1 100	1 200	1 400
Stainless steel	250	0	100	180	320	400	550	590	750	840	845	850	950	1 150
Silver	350	100	0	80	220	300	450	490	650	740	745	750	850	1 050
Nickel or Monel	430	180	80	0	140	220	370	410	570	660	665	670	770	970
Copper	570	320	220	140	0	80	230	270	430	520	525	530	630	830
Brass	650	400	300	220	80	0	150	190	350	440	445	450	550	750
Tin	800	550	450	370	230	150	0	40	200	290	295	300	400	600
Lead	840	590	490	410	270	190	40	0	160	250	255	260	360	560
Soft steel	1 000	750	650	570	430	350	200	160	0	90	95	100	200	400
Aluminium 99.5%	1 090	840	740	660	520	440	290	250	90	0	5	10	110	310
Hard steel	1 095	845	745	665	525	445	295	255	95	5	0	5	105	305
Cadmium	1 100	850	750	670	530	450	300	260	100	10	5	0	100	300
Chromium	1 200	950	850	770	630	550	400	360	200	110	105	100	0	200
Zinc	1 400	1 150	1 050	970	830	750	600	560	400	310	305	300	200	0

When filters are used, care should be paid to corrosion problems. The metallic filter cases should have a non-corroding surface in order to ensure a low contact resistance (approximately 100 $\mu\Omega$) of the case to the interface with the victim apparatus throughout an extensive period of time.

The telecommunication cable termination on insulation transformers, surge protective devices or systems shall be protected from corrosion, particularly if installed outside of a controlled environment. Corroded contacts or cable termination affect the installed protection arrangements and increase the impedance of the mechanical joint/connection to the building earthing arrangements.

Protection of any contact surfaces within any protection device installed in an outside environment shall be assured.

7 Additional installation practices for optical fibre cabling

7.1 General

This clause details the particular recommended practices for the installation of optical fibre cable and closures.

Recommended optical fibre cabling test schedules are contained in EN 50346.

Additional guidance on the installation of optical fibre cabling out side of a building is contained in EN 50174-3.

7.2 General precautions

Suitable protective caps should be fitted to the exposed ends of the optical fibre cable. These should not be removed until required and should be replaced or renewed as required until the optical fibre cable has been correctly terminated.

7.3 Pre-installation practices

The optical fibre cable should be tested for compliance with its specification prior to further handling. Installed (laid) optical fibre cable acceptance tests should be undertaken to avoid contractual disputes.

The installer should determine any measures necessary to prevent the optical fibre within the optical fibre cable experiencing direct stress following installation. Where long vertical runs are proposed, optical fibre cables need, in some cases, to deviate from the vertical at intervals as recommended by the manufacturer (by the inclusion of short horizontal runs or loops).

7.4 Optical fibre cable practices

A minimum agreed length of optical fibre cable should be allowed at each closure position. This is to enable subsequent access to the closure and to ensure sufficient length for cable management, acceptance testing and also to reduce the problem of damage to the end of the optical fibre cable.

7.5 Final assembly of closures

Labels according to series EN 60825 should be applied adjacent to all accessible optical interfaces (see 4.5).

7.6 Termination practices

7.6.1 Jointing/termination of optical fibres

The use of either fusion splicing or mechanical jointing techniques provides a permanent stable, low attenuation connection of optical fibres.

The performance of a splice is dependent upon the capability of the technique, the workmanship applied to achieve the splice and the subsequent workmanship applied to protect the splice to ensure satisfactory operational lifetime.

Mechanical spliced joints are achieved by the alignment of the two optical fibre ends within a protective sleeve. Manufacturers' recommended instructions for protection and retention of the optical fibres should be observed.

The mechanical splice is generally retained by either friction or adhesive bonds to the optical fibre. In some cases it is necessary to provide further strain relief for the completed joint.

Fusion spliced joints are achieved by welding the core and cladding regions of the two optical fibre ends. The fusion splice should be protected by a suitable sleeve or splint.

The fusion splice is generally retained within the protective sleeve by either friction or adhesive bonds to the optical fibre. In some cases it is necessary to provide further strain relief for the completed joint.

Termination can be done by direct application of connectors to the installed optical fibre, e.g. glueing techniques, or splicing or mechanical connection of a pre-manufactured pigtail to the optical fibre of the installed optical fibre cable.

Labelling of optical fibre installations should be such that the polarisation of duplex optical fibre connections is known and consistent throughout the installation.

During the direct application of connectors to the installed optical fibre, the recommended installation procedures should be followed.

Connectors applied to optical fibres should be subjected to visual inspection as defined in EN 50346.

7.6.2 Optical fibre management

All splice joints and their strain relief mechanisms should be fixed within the optical fibre management system of the closure.

Under no circumstances shall splices be left unsupported

Annex A (informative) Coupling mechanisms and countermeasures

A.1 General

EMC performance of installed cabling is influenced by several different coupling phenomena which may have adverse effects at different frequencies. These situations are explained in the following.

A.2 Countermeasures against galvanic or common mode impedance coupling

Impedances in common mode current paths, if they cannot be avoided, should be kept as low as possible.

The main countermeasures to minimise the effects of common mode impedance coupling are:

- a) reduce the common mode impedance;
- b) reduce the amplitude of the disturbing currents.

A.3 Countermeasures against capacitive coupling

The main countermeasures to minimise the effects of capacitive couplings are:

- a) symmetrical transmission on balanced cabling

Conductors are identically exposed to the same electric field. Induced interfering voltages in both conductors have the same polarity and amplitude; the wanted differential mode signal remains unaffected up to certain frequencies. The interference appears as an unwanted common mode signal. Depending on its common mode rejection ratio, the correct operation of connected equipment is influenced by the presence of common mode voltages;

- b) screened cabling and/or metallic or composite cable management systems specially designed for EMC purposes

diminish the influence of electric fields if the cable screen or cable management system (see Figure A.1):

- is continuous along the cabling channel;
- is earthed and bonded as detailed in this standard.

Since the cable management system is fixed at earth potential, unwanted electric charges cannot cause voltage rises. At high frequencies the method of grounding of the screen at the cable ends is very important. Even a few centimetres of unscreened lead (pigtail) can compromise the screen effectiveness.

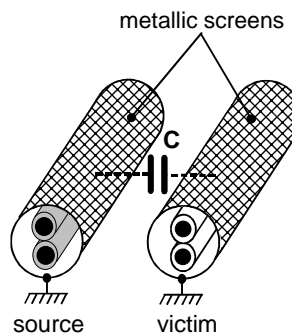

Figure A.1 - Screened cables reduce capacitive coupling

A.4 Countermeasures against inductive coupling

The main countermeasures to minimise the effects of inductive couplings are:

- a) Symmetrical transmission on balanced cabling

Single conductors are twisted together; the surfaces of possible induction loops are very small. Only few magnetic field lines penetrate these loops. Adjacent twists create induced voltages in phase opposition which as a consequence cancel each other. The induced difference between the two conductors approaches close to zero. On the other hand a common mode disturbance is induced in the loop formed with the (twisted) conductors and the earth. The influence on the equipment is reduced by the common mode rejection of the connected port.

b) Screened cabling

Screened cabling provides - depending on the frequency and the materials used - protection against magnetic fields if the screen is earthed at both cable ends. In general, no adequate protection against magnetic fields is given, if the screen of the cable is not connected to ground. Exceptions to this rule exist e.g. when the unconnected cable screen is placed on the surface of or near to an earthing structure.

c) Metallic or composite cable management systems specially designed for EMC purposes

Metallic or composite cable management systems specially designed for EMC purposes can diminish the influence of magnetic fields if:

- elements are properly bonded;
- the cable management system has a low impedance earthing at both ends;
- the frequency is above a minimum value (depending on material and thickness).

The disturbing magnetic field also induces a current in the loop built up with the cable management system and the earth. This current creates an opposite magnetic field which compensates the initial one. At minimum the effect can be improved with a Parallel Earth Conductor to cable. The PEC principle is explained in IEC/TR 61000-5-3.

Since both capacitive and inductive coupling exist simultaneously, the composite takes into account the effect of each contributor, unless one of the two may be neglected.

A.5 Countermeasures against radiated coupling

The main countermeasure to minimise the effects of radiated couplings are:

a) for field to cable (see Figure A.2)

reduce the antenna effect of the victim cable (reduce the cable height h , put the cable into metallic or composite cable management systems specially designed for EMC purposes, use screened cables correctly bonded, add earthed parallel conductors, add filters or ferrite beads, etc.);

b) for field to loop (see Figure A.3)

reduce the victim loop area (reduce height and length of the cable, all the solutions of a) are also valid);

c) use the Faraday cage principle

A screened cable connected at both ends with the screening of the equipment is a possible solution; the equipment need not be earthed in the case of high frequencies. When connecting both equipment to earth, current loops should be avoided or at least minimised. Radiated coupling decreases with distance and through the application of symmetrical transmission on balanced cabling.

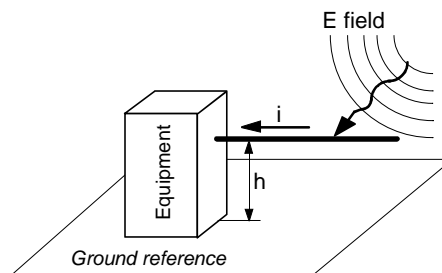

Figure A.2 - Electrical field to cable, capacitive coupling example

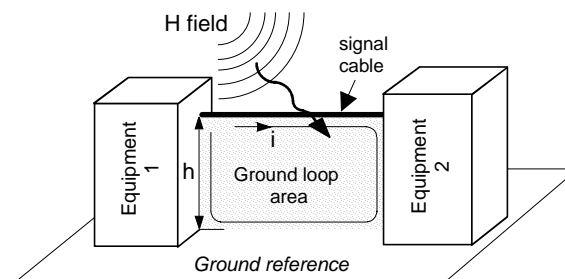

Figure A.3 - Magnetic field to loop, inductive coupling example

A.6 The EMC concept

A.6.1 Questions to be answered in view of the practical realization of EMC concepts

Use the EMC checklist of Table A.1 step by step and set checkmarks as appropriate.

Table A.1 - EMC Checklist

Aspects to be considered		Answer		Comment
		Yes	No	
1	Building			
1a)	Existing building?	Δ ¹⁾	○ ¹⁾	
1b)	New building projected?	Δ	○	
1c)	New building existing?	Δ	○	
1d)	New and existing building mixed?	Δ	○	
1e)	Hospital?	Δ	○	
2	Power distribution system			
2a)	TN-S?	○	○	Best solution
2b)	TN-C-S?	Δ	○	
2c)	TN-C?	Δ	○	
2d)	TT?	Δ	○	
2e)	IT?	Δ	○	
3	Disturbing sources			
3a)	Transformer station?	Δ	○	
3b)	Proximity to electrical traction?	Δ	○	
3c)	Proximity to high voltage power lines?	Δ	○	
3d)	Arc welders?	Δ	○	
3e)	Frequency induction heaters?	Δ	○	
3f)	Transmitting equipment (radio, television, wireless telephone and radar)?	Δ	○	
3g)	Does the installed equipment ²⁾ comply with relevant European EMC-Standards?	○	Δ	
3h)	Power cables screened?	Δ	○	
3i)	Proximity to coaxial or unbalanced cabling?	Δ	○	
4	Customer requirements concerning security			
4a)	Very sensitive application(s)?	Δ	○	
4b)	Hospital environment?	Δ	○	
5	Structure of the existing and/or future earthing and bonding network			
5a)	Mesh topology, CBN or MESH-BN?	○		
5b)	Star topology, IBN or MESH-IBN?	Δ		
5c)	Trunk structure?	Δ		
5d)	More than one answer a),b),c)	Δ		
6	Cable management systems, raised floors			
6a)	1. generic cabling parallel to power lines 2. premises cabling parallel to power lines	Δ Δ	○ ○	
6b)	Plastic or metallic (aluminium or steel) cable management systems	Δ Δ Δ	○ ○ ○	Plastic Steel Aluminium
6c)	Plastic or metallic separation between information technology cabling and power lines?	Δ ○ ○	Δ Δ Δ	Plastic Steel Aluminium
6d)	Are the metallic or composite cable management systems specially designed for EMC purposes earthed repeatedly or at least at both ends?	○	Δ	
6e)	Is the cabling between buildings carried out with metallic cables?	Δ	○	
NOTE 1 ○ = No action required Δ = See A.6.2.				
NOTE 2 This refers not only to the connected equipment but also to other equipment in the environment (e.g. copiers, fluorescent lighting).				

A.6.2 Actions resulting from the answers of Table A.1

A.6.2.1 Building

1a) Existing building?

Yes Old buildings have the highest probability of critical electricity distribution systems and the earthing and bonding system is based on very old concepts. In addition some of the older buildings are protected by special laws which do not allow all actions to be performed in the building. For example: Drilling of holes not allowed everywhere, removal of wooden parts is forbidden, technology has to fit without disturbing the architecture, etc.

Extremely critical:

Complete and very precise analysis required. Answer all questions and setup action plan to make sure that installation will work. Corrective actions are costly, therefore early customer information is required for decisions and budget planning.

For information about earthing and bonding see 6.7.

1b) New building projected?

Yes use the opportunity to influence the planning activities of building planner to have an integrated EMC-concept e.g.

- electricity distribution system TN-S (see 6.4);
- space for cable management systems, cabinets;
- provision of appropriate earthing and bonding at the required location (see 6.7);
- separation of generic cabling paths from fluorescent illumination (see 6.5.3).

1c) New building existing?

Yes same problems as 1a) except:

- electricity distribution system TN-S generally existing (see 6.4);
- equipotential bonding network available (see 6.7).

1d) New and old building mixed?

Yes The combination of old and new buildings is as critical as installations in old buildings. The combination of different systems creates many problems.

Check, whether the electricity distribution system is of the same type, preferably TN-S system.

Possible solutions:

- all buildings have TN-S systems (see 6.4);
- interconnect both PE's of the TN-C systems on the main earthing terminal (see 6.7);
- use of isolation transformers (see 6.10);
- use of optical fibre links without metallic sheath (see clause 7);

For information about earthing and bonding see 6.7.

1e) Hospital

Yes Installations in hospitals require different precautions due to the following reasons:

- Influence of the information technology signals to medical equipment: Equipment used for intensive care, heart pacemaker, monitoring devices etc.
- Influence of the medical equipment signals to the information technology signals: Equipment which sends strong signals, microwaves, etc.
- Higher class of fire precautions: Look for all relevant laws and regulations for the hospital area and follow them strictly. No exceptions are allowed.

A.6.2.2 Electricity distribution system

2a) TN-S system

Yes Best EMC solution. For further information see 6.4.

2b) TN-C-S system

Yes For further information see 6.4.

Screened cabling in combination with TN-C/TN-C-S and equipment with protection class I requires interruption of screen and generally the installation of a protective device bridging the interruption.

2c) TN-C system

Yes The remark in 2b) concerning the interruption of the screen remains valid for 2c).

2d) TT system

Yes For further information see 6.4.

2e) IT system

Yes For further information see 6.4.

A.6.2.3 Disturbing sources

3a) Transformer station

Yes Production of disturbing magnetic fields (50 Hz). Rise of earth potential.

3b) Proximity to electrical traction

Yes See 3e).

3c) Proximity to high-voltage power lines

Yes See 3e).

3d) Arc welders

Yes See 3e).

3e) Frequency induction heating

Yes High current low frequency phenomena are very common in this environment.

Possible solutions:

- make sure to use equipment complying with enhanced immunity requirements;
- avoid galvanic and inductive coupling ;
- request manufacturers' information concerning field strengths in relation to the distances;
- use:
 - i) screening techniques;
 - ii) sufficient distance from the high current installation (see 6.5);
 - iii) adjacent routing of power circuits and signal cables for the information technology equipment (see 6.5);
 - iv) screened power and signal cables; the screen shall be bonded to the equipment at both ends (see 6.3);
 - v) thickened wall steel conduit earthed at many points;
 - vi) optical fibre links without metallic sheath (see clause 7).

3f) Transmitting equipment (radio, television, wireless telephone and radar)

- Yes 1) Fixed transmitter installation: measure field strength and install components according to the measured values.
- 2) Movable transmitter: Analyse the worst case situation of transmitting equipment, ask producer or PTT about signal levels and install components according to the given values.
- The earthing and bonding concept has to be checked in detail to have optimum protection (see 6.7).

3g) Does the installed equipment comply with relevant European EMC standards?

- No Use only equipment complying with the relevant EMC-requirements (CE marking).
- Special applications (coexistence with other systems) may require more stringent installation practices on equipment complying with enhanced requirements.

3h) Power cables screened?

- Yes Screened power cables are very seldom installed but in computer centers and similar you may find screened power cables. information technology installations nearby are less critical but make sure that the power cable screens are included in the earthing and bonding concept (see 6.3 and 6.7).

3i) Proximity to coaxial or unbalanced cabling

- Yes Under consideration.

A.6.2.4 Customer requirements concerning security

4a) Very sensitive application(s)

- Yes Some areas require extreme precaution to prevent outages due to EMC phenomena, e.g. production control of chemical industry, applications with risk to life, etc. Very sensitive installations require highest quality components, highest workmanship quality, backup lines, backup hubs, automatic backup procedures, high level of documentation, documentation of backup activities, etc.

4b) Hospital environment

- Yes Hospital environments have to be analyzed to minimize EMC risk to life support machine.
- No disturbance of health controlling/monitoring devices, etc. Installation only possible when hospital business will allow.

A.6.2.5 The structure of the existing and/or future earthing and bonding network

5a) Mesh topology, CBN or MESH-BN?

- Yes Principle configurations see 6.7.

5b) Star topology, IBN or MESH-IBN?

- Yes Principle configurations see 6.7.

5c) Trunk structure

- Yes Principle configurations see 6.7.

5d) More than one answer (a/b/c)

- Yes Under consideration.

A.6.2.6 Cable management systems, raised floor

6a) Parallel to power lines

Yes Minimum distances shall be respected; however parallel routing is recommended in order to avoid large induction loops (see 6.5).

6b) and 6c) Plastic or metallic cable management systems, separation

Yes Plastic cable management systems assure a well defined separation distance within guaranteed limits (see 6.5).

Metallic or composite cable management systems specially designed for EMC purposes allow less distance if metallic separation (correctly bonded) is used (see 6.7).

6d) Are the metallic sections earthed?

No Install the earth according to the standards (see 6.7).

6e) Cabling between buildings carried out with metallic cables?

Yes Overvoltage protection required.

Bibliography

- EN 50081 series, *Electromagnetic compatibility – Generic emission standard*.
- EN 50082 series, *Electromagnetic compatibility – Generic immunity standard*.
- EN 50083 series, *Cable networks for television signals, sound signals and interactive services*.
- EN 50098-1, *Customer premises cabling for information technology - Part 1: ISDN basic access*.
- EN 50098-2, *Customer premises cabling for information technology - Part 2: 2048 kbit/s ISDN primary access and leased line network interface*.
- EN 50346 ⁴⁾, *Information technology - Cabling installation - Testing of installed cabling*.
- HD 384.2 S1, *International Electrotechnical Vocabulary - Chapter 826: Electrical installations of buildings (IEC 60050-826:1982)*.
- HD 384.4.442 S1, *Electrical installations of buildings – Part 4: Protection for safety - Chapter 44: Protection against overvoltages – Section 442: Protection of low-voltage installations against faults between high-voltage systems and earth*.
- ENV 61024-1, *Protection of structures against lightning – Part 1: General principles (IEC 61024-1:1990, modified)*.
- ETS 300 253, *Equipment Engineering (EE) - Earthing and bonding of telecommunication equipment in telecommunication centres*.
- IEC 60050-161, *International Electrotechnical Vocabulary - Chapter 161: Electromagnetic compatibility*.
- IEC 60050-195, *International Electrotechnical Vocabulary - Chapter 195: Earthing and protection against electric shock*.
- IEC 60050-604, *International Electrotechnical Vocabulary - Chapter 604: Generation, transmission and distribution of electricity – Operation*.
- IEC 60364-5-548, *Electrical installations of buildings - Part 5: Selection and erection of electrical equipment - Chapter 548: Earthing arrangements and equipotential bonding for information technology installations*.
- IEC/TR 61000-5-2, *Electromagnetic compatibility (EMC) - Part 5: Installation and mitigation guidelines - Section 2: Earthing and cabling*.
- IEC/TR 61000-5-3, *Electromagnetic compatibility (EMC) - Part 5-3: Installation and mitigation guidelines – HEMP protection concepts*.
- IEC/TR 61662, *Assessment of the risk of damage due to lightning*.
- R044-001, *Safety of machinery – Guidance and recommendations for the avoidance of hazards due to static electricity*.
- R064-004, *Electrical installations of buildings – Part 4: Protection for safety – Chapter 44: Protection against overvoltages – Section 444: Protection against electromagnetic interferences (EMI) (IEC 60364-4-444:1996, modified)*.
- Recommendation ITU-T K.20, *Resistibility of telecommunication switching equipment to overvoltages and overcurrents*.
- Recommendation ITU-T K.21, *Resistibility of subscriber's terminal to overvoltages and overcurrents*.
- Recommendation ITU-T K.44, *Resistibility tests for telecommunication equipment exposed to overvoltages and overcurrents*.
- Recommendation ITU-T K.45, *Resistibility of access network equipment to overvoltages and overcurrents*.

⁴⁾ In preparation by TC 215